

BIXOLON

User Manual

XLR-40M, XLR-40J

Laser Label Printer

Ver. 1.01



Table of Contents

Copyright..... 4
Cautions and Warnings 5
Laser Safety Precautions 7
Safety Devices 9

Manual Guide..... 10
Manual Symbols Guide..... 10

1. Product Information 11
 1-1 Main Specifications..... 11
 1-2 Package Contents 13

2. Main Names and Functions of the Equipment..... 14
 2-1 External Components..... 14
 2-1-1 Equipment Switches..... 14
 2-1-2 Equipment LCD 16
 2-1-3 Equipment LED 17
 2-1-4 Main External Parts 18
 2-2 Internal Components 20

3. Installation and Usage Instructions..... 22
 3-1 Installation Location 22
 3-2 Power and Communication Connections 23
 3-3 Media Installation (External Media Installation Appendix) 25
 3-4 LM Driver Installation..... 27

4. Printer Detailed Settings 29
 4-1 Printer Setup Mode 29
 4-2 LM Driver 30
 4-2-1 LM Driver Execution Sequence 30
 4-2-2 LM Detailed Description of LM Driver Functions 31
 4-2-3 Adding Media Size 40

5. Equipment Maintenance 42
 5-1 Maintenance and Inspection Methods 42
 5-2 Scanner Lens Cleaning Method 43

6. Troubleshooting..... 45
 6-1 Symptoms and Countermeasures 45
 6-2 Detailed Countermeasures..... 47
 6-2-1 Sensor Amplifier Sensitivity Adjustment 47
 6-2-2 Roller Pressure Adjustment 48

6-2-3 How to Check Normal Installation of LM Driver 49

7. Appendix 50

7-1 External Views 50

Copyright

© BIXOLON Co., Ltd. All rights reserved.

This user manual and the works used in the product are protected by copyright law.

No part of this manual or the works used in the product may be reproduced, stored, or transmitted in any form or by any means without prior written consent from BIXOLON Co., Ltd.

The information provided does not apply to any other products

BIXOLON assumes no responsibility for any direct or indirect damages caused by the use of this information.

·The BIXOLON logo is a registered trademark of BIXOLON Co., Ltd.

·All other trademarks or product names are the property of their respective companies or organizations.

BIXOLON Co., Ltd. continuously improves its products for better performance and quality.

Therefore, specifications and contents of this manual are subject to change without prior notice.

Cautions and Warnings



Please follow these instructions to use the product correctly and to prevent danger or property damage.

Do not connect multiple products to a single outlet. Do not use loose outlets. Use standard outlets only. Always connect the power cord to a grounded outlet. **Risk of electric shock or fire.**



Always use genuine products supplied by BIXOLON. **We are not responsible for damage caused by the use of imitation or recycled products.**



Do not bend or pull the power cord excessively. Insert the power cord firmly all the way in to avoid looseness. When unplugging, always hold the plug, not the cord. Do not unplug the power cord while using the product. **Risk of electric shock or fire.**



Keep small accessories or packaging materials out of children's reach. Be careful to prevent children from swallowing them. Improper handling may cause injury. **If swallowed, consult a doctor immediately.**



Do not touch the plug with wet hands when plugging in or unplugging. If the plug or outlet is dirty, clean it with a dry cloth. **Risk of electric shock or fire.**

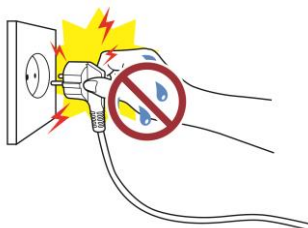

Do not place heavy objects on the cord. **Risk of electric shock or fire.**

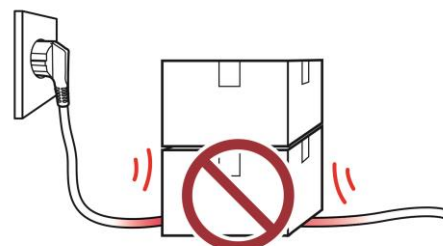

If you notice abnormal sounds, burning smells, or smoke, turn off the power and unplug immediately. If the product is dropped or damaged, turn off the power and unplug immediately. Do not subject the product to shock. **Risk of fire. Risk of product damage.**

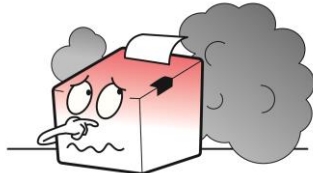

Install the product in a well-ventilated area, away from walls. Do not install in places with heavy dust, extreme temperatures, high humidity, or special environments like airports or stations where continuous use may cause serious quality issues. **It may cause fire due to internal overheating. Consult your dealer before installation.**



Install the product securely to prevent it from falling. Turn off the power and disconnect all cables before moving the product. Do not drop the product while carrying it. **Risk of product damage.**



Do not disassemble, repair, or modify the product yourself. **Contact your dealer for service.**



Do not allow foreign substances inside the product. Do not place heavy objects, liquids, or metals on the product. **Risk of fire. Risk of product damage.**



Refer to the BIXOLON website for headquarters and branch contact information. If problems occur, contact your dealer. Repair videos are also available on the BIXOLON website (www.bixelon.co.kr).



Laser Safety Precautions

This equipment is classified as Class 1 laser equipment under IEC 60825-1:2014. This means it is safe for general use. All safety precautions in this manual must be followed to ensure safe operation.

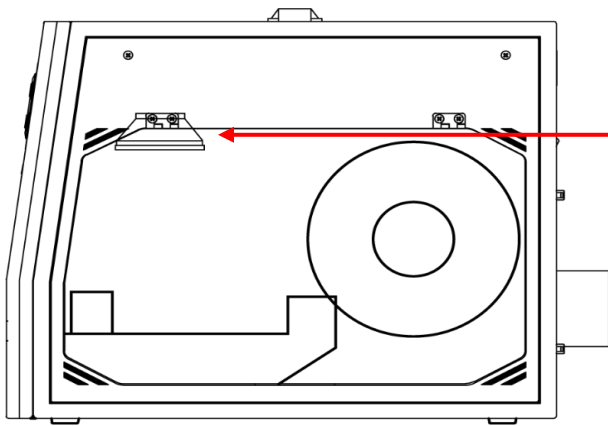

The laser is emitted from this position.



Warning: Laser radiation may cause injury to eyes or skin.

Controls and adjustments not specified in this manual may result in hazardous exposure to laser radiation. Since exposure to the laser beam may harm the human body (such as eyes or skin), observe the following precautions.

(1) Do not directly view the laser beam, reflections, or scattered light. Direct exposure to the eyes may cause blindness.

If you must view the laser spot, wear protective goggles for eye safety. Use protective goggles with an applicable wavelength range of 1,050 to 1,200 nm that can protect against the 1,064 nm wavelength of the Nd:YAG laser used in this equipment. Even when wearing protective goggles, take sufficient care to avoid exposure to direct laser beams or reflected beams.

(2) Ensure that no part of your body carelessly enters the printing area while the equipment is operating. This may cause burns or other injuries to the skin. The equipment is fundamentally equipped with an interlock function, which immediately stops laser emission when the door is opened.

Therefore, never attempt to modify the equipment or disable its safety devices.

(3) Do not use this equipment near flammable materials. Also, do not place combustible materials or gases (such as organic solvents) near the laser irradiation point. They may ignite and cause fire.

(4) Ensure that no conductive foreign matter or flammable substances enter the equipment during operation or storage.

XLR-40 Series

- (5) When marking on non-designated media such as other materials, metals, or plastics, use a dust collection system to remove dust and fumes so they are not inhaled. Depending on the printed material, these may be harmful to the human body.
- (6) When using a dust collector, make sure dust does not accumulate inside the ducts and clean them regularly. Accumulated dust may cause fire or equipment malfunction.
- (7) Do not operate this equipment in any manner other than the operating methods described in this manual. There is a risk of exposure to laser radiation.
- (8) Do not use this equipment in environments subject to vibration or shock. Laser focus may be misaligned, resulting in reduced print quality, and optical parts inside the equipment may be damaged.
- (9) Take care to ensure that the scanner lens does not become contaminated. If contamination occurs, clean it according to the scanner lens cleaning method described in this manual.

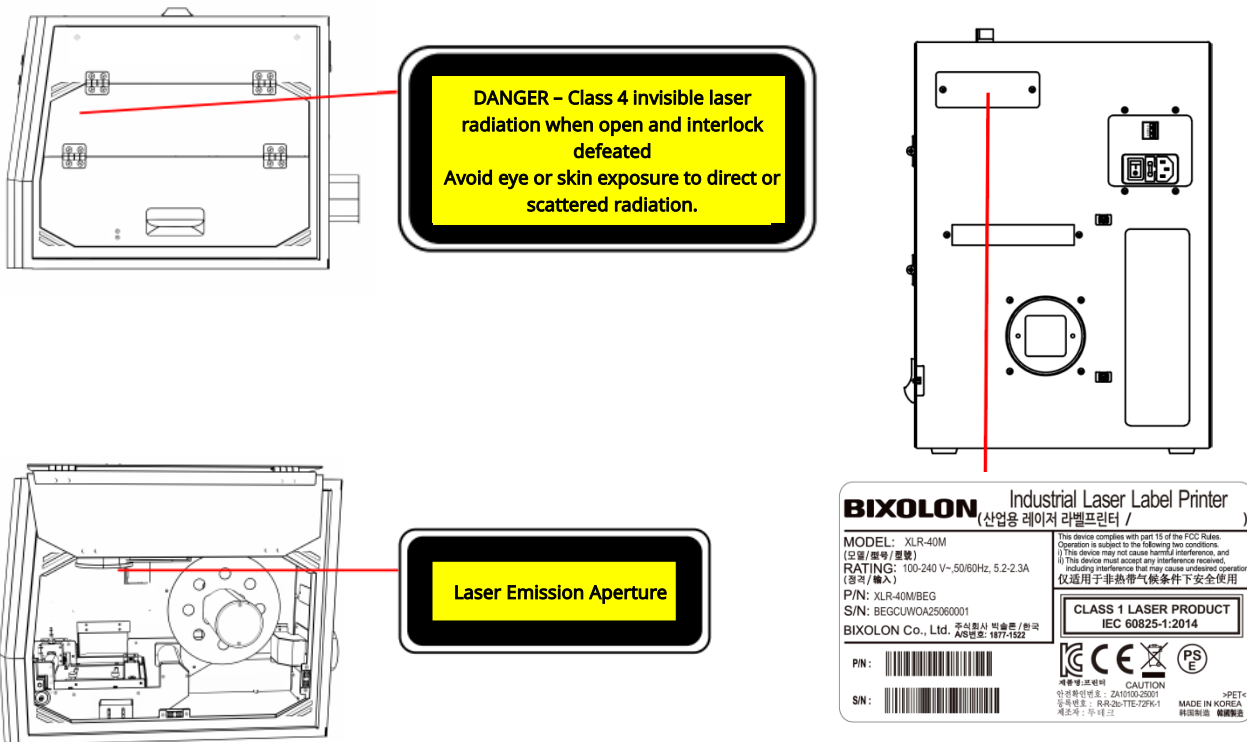

Image of the side cover opened





< Position of the Laser Safety Label >



The company assumes no responsibility for accidents or damages caused by failure to follow the instructions in this manual.

Safety Devices

This equipment is equipped with safety devices.

Device Image	Name	Description
	Emergency Stop Button	Stops the equipment immediately in case of emergency. Prevents safety accidents by halting the equipment.
	Interlock Switch	An interlock switch is located at the lower part of the side door; if the cover is opened, laser emission is immediately cut off.
	Mark Time Limit	Limits the maximum laser marking time. Stops laser marking when the set time is exceeded. Prevents the risk of continuous laser emission in emergencies.
	Safety Label	Safety-related labels are attached to the equipment. Refer to their contents and take proper precautions.

Manual Guide

This manual provides basic information, installation, usage, and inspection guidelines for the printer. Read this manual carefully before use to protect user safety and prevent property damage.

The equipment manuals are divided into the following types for different purposes.

- 1) Quick Manual: Contains simplified content with illustrations for quick user understanding.
- 2) User Manual: Provides general information for users to understand basic equipment operation.
- 3) Service Manual: Provides complete information for equipment managers on maintenance and service.

Manual Symbols Guide



Caution/Warning

Indicates information that may cause physical injury, property damage, or data loss.



Note

Provides additional information about equipment functions and performance.

1. Product Information



1-1 Main Specifications

XLR-40	
Print Characteristics	
Print Method	Laser
Print Speed	3,000mm/s
Print Resolution	Max 2,000dpi
Print Width	108mm
Print Length	108mm
Sensor	Transmissive (Adjustable Sensitivity)
Approvals	CE, FCC, KC, PSE
Media Characteristics	
Media Type	Gap
Media Width	17 to 114mm
Media Roll Diameter	Up to 180mm
Media Thickness	0.08 ~ 0.5mm
Supply Method	Easy Paper Loading
Inner Core	76mm
Laser Characteristics	
Laser Type	Fiber
Laser Power	Up to 20W
Cooling Method	Air-cooled
Wavelength	1064nm
Frequency Range	XLR-40M: 30 ~ 60kHz / XLR-40J: 1 ~ 600kHz
Pulse Energy	XLR-40M: 0.7mJ / XLR-40J: 0.8mJ
Laser Safety Certification	IEC 60825-1:2014
Laser Safety Class	Class 1 laser product
Physical Characteristics	
Dimensions (WxLxH)	290 x 485 x 405 mm (11.42 x 19.09 x 15.94 inch)
Weight	XLR-40M: 31.2kg / XLR-40J: 30kg
Electrical	100-240V 50/60Hz
Display	STN/Blue LCD(Backlight LED)

XLR-40 Series

Performance Characteristics	
Interface	USB
Environment Characteristics	
Temperature	Operating: 15 ~ 35°C Storage: -10 ~ 60°C (must not be frozen)
Humidity	30 ~ 85% RH (must not cause condensation)
Software	
Driver/Utility	Windows Driver
Fonts/Graphics	
Fonts	TTF Window Font
Graphics	Bitmap, JPG
Accessories	
Standard	Power Cord, USB Cable

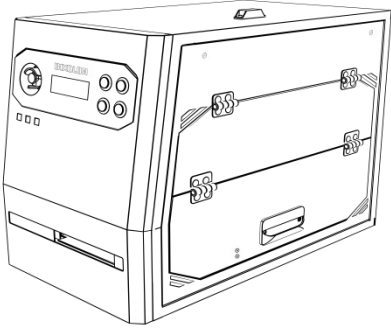
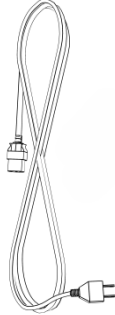
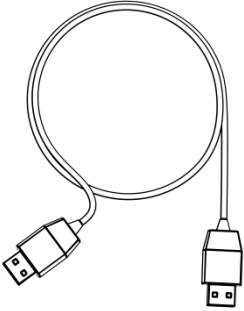
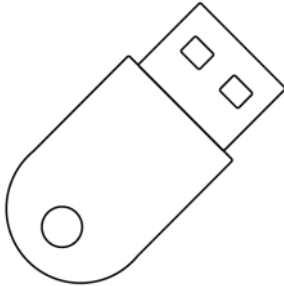
1-2 Package Contents

List of Contents	
	
<p>Laser Label Printer</p>	<p>Power Cable</p>
	
<p>USB 3.0 Cable</p>	<p>USB Memory</p>
	<p>레이저 안전 서약서</p> <p>본인만 레이저기로부터 발생하는 레이저 광선을 사용하지 않아, 기타 사람에 발광할 수 있는 위험성을 충분히 숙지하였으며, OSA 사용 중 발생할 수 있는 모든 안전사항을 숙지합니다.</p> <ol style="list-style-type: none"> 본 제품설명서에서 규정하는 조건 및 안전 수칙을 철저히 준수합니다. 레이저 광선, 전선류 등 육안 관찰을 적당 주의 합니다. 레이저광은 피부 화상, 눈부임, 눈손상(눈부임) 등을 유발 1000~1200mW이상 저출력 수 있는 경우 눈부임현상 유발합니다. 작업 중 레이저 광선 노출 시 발생하는 레이저 광선을 피하고, 레이저 기계를 작동할 때 레이저 광선 차단기 작동하지 않도록 합니다. 작업이 끝난 후 레이저 광선 차단기 작동 여부를 점검하고, 안전을 위해 레이저 광선 차단기 작동 여부를 확인합니다. 작업이 끝나면 레이저 광선 차단기 작동 여부를 점검하고, 안전을 위해 레이저 광선 차단기 작동 여부를 확인합니다. 레이저 광선 차단기 작동 여부를 점검하고, 안전을 위해 레이저 광선 차단기 작동 여부를 확인합니다. 본 제품설명서에서 규정하는 안전 수칙을 철저히 준수합니다. 본인만 레이저기로부터 발생하는 레이저 광선을 사용하지 않아, 기타 사람에 발광할 수 있는 위험성을 충분히 숙지하였으며, OSA 사용 중 발생할 수 있는 모든 안전사항을 숙지합니다. <p>본인만 레이저기 안전 수칙을 숙지하였으며, 이를 준수할 것을 서약합니다.</p> <p>서약인: _____ 나이: _____ 성명: _____ (서명) 일자: _____ (일자)</p>
<p>Quick Manual</p>	<p>Laser Safety Agreement</p>



2. Main Names and Functions of the Equipment



2-1 External Components



<Image of External Equipment>

2-1-1 Equipment Switches

Switch Image	Name	Description
	EMERGENCY STOP	Press the emergency stop switch to cut off power in emergencies. When pressed, the equipment stops immediately; to restart, release it by turning in the arrow direction.
	PAUSE	Stops after finishing the current page being printed. Press the PAUSE switch once more to resume work.
	1 (BACK FEED)	Moves the media backward by one step.







	2 (CANCEL)	Cancels all ongoing work. Pressing it again in Cancel state returns the system to Ready state.
	FEED	Moves the media forward by one step.



After pressing button 1, if you want to reprint at the original position, press the FEED button to realign the media.

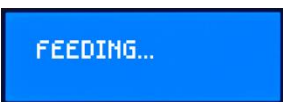

2-1-2 Equipment LCD

Displays equipment status and necessary setup information.

LCD Screen	LCD Message	Description
	INTERLOCK	The interlock function ensures the laser operates only when the door is closed for safety. When interlocked, the Red Mark option allows checking the laser emission path using Red Print or Red Outline functions.
	READY	The equipment is ready for operation. Printing begins once a print command is given in this state.
	PRINTING	Laser beam is being emitted for printing.
	FEEDING	Media is being fed.
	PAUSE	The operation is paused.
	CANCEL	The operation has been canceled.
	TIMEOUT PAUSE	The equipment has stopped because the media or the media pressure lever is open. To return to READY state, close the media pressure lever and press the Pause button twice to realign the media. (Refer to 3-3 Media Installation.)

2-1-3 Equipment LED

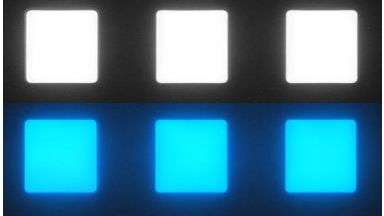
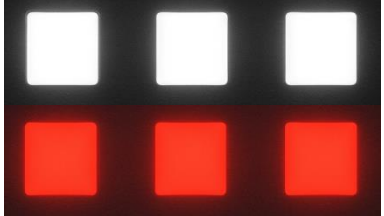

The LED color changes depending on equipment status.

LED Light	Equipment Status	Light Condition
	Preparing after equipment and driver are running.	White
	READY State	Blue
	PRINTING State	White and blue blinking alternately
	INTERLOCK State	White and red blinking alternately



2-1-4 Main External Parts



< Image of Rear Equipment >

Part Image	Name	Description
	USB Connector	Used to connect the communication cable between the PC and the equipment. Through the LM driver software provided, the laser and scanner can be controlled, and printing content and quality can be configured.
	Power Switch	Requires AC 220 V, 50~60 Hz, 5A power supply matching the equipment's rated voltage.
	Exhaust Port	Exhaust port for connecting a dust collector when using non-designated media. Not necessary when using designated media or media that does not produce smoke or odor.

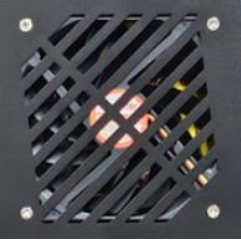
XLR-40 Series

 A square fan with a black metal grille and four screws at the corners.	Equipment Cooling Fan	Fan for cooling the equipment. Attached to the side panel of the equipment.
 A rectangular fan with a black metal grille.	Laser Cooling Fan	Cooling fan built into the laser source.



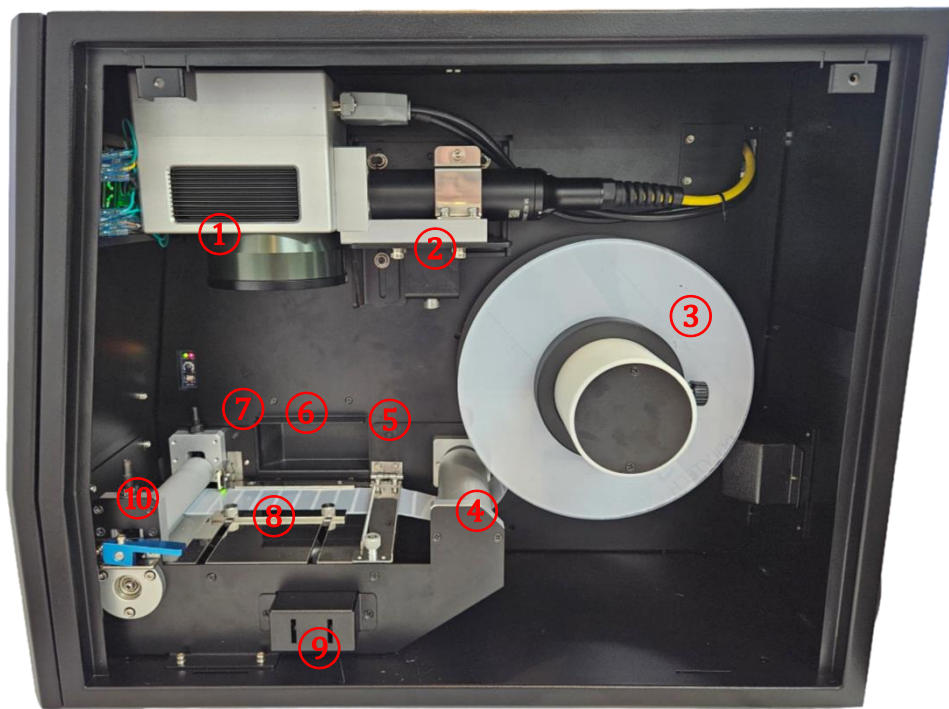

- Always connect to a grounded power source when supplying power. If not grounded, electromagnetic noise may cause malfunction.
- For laser heat dissipation, install the equipment about 30 cm away from the wall behind it.

2-2 Internal Components

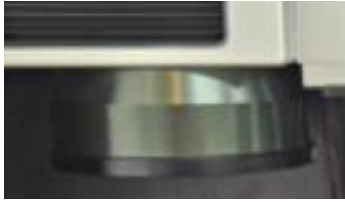

< Image of Internal Equipment >

Name	Image	Description
(1) Scanner Head		This is where the laser beam is emitted. (If the scanner cover is closed, please open it.)
(2) Laser Focus Adjustment Knob		This knob is used to adjust the laser focal distance. Turn it to adjust the position.
(3) Media Roll Guide		A device that secures the media for stable feeding without shifting. Tighten the screw to fix it.

XLR-40 Series

<p>(4) Media Tension Roller</p>		<p>A device that keeps the media from lifting upward. Pass the media beneath the roller.</p>
<p>(5) Media Tension Sub Guide</p>		<p>An auxiliary device that prevents the media from lifting upward. Lift slightly, pass the media underneath, then lower it.</p>
<p>(6) Exhaust Inlet</p>		<p>An exhaust duct connected to the external exhaust system for dust collection. Use this duct for dust collection when necessary.</p>
<p>(7) Media Position Sensor</p>		<p>A sensor for controlling the media position. It detects media gap differences during operation and feeding to ensure correct positioning.</p>
<p>(8) Media Feeding Guide</p>		<p>A device that holds the media straight during feeding.</p>
<p>(9) Interlock Switch</p>		<p>An interlock switch is located at the lower part of the side door; if the cover is opened, laser emission is immediately cut off.</p>
<p>(10) Media Pressure Lever</p>		<p>A lever that adjusts the feeding pressure roller. It secures the roller and media for proper feeding.</p>

3. Installation and Usage Instructions

3-1 Installation Location

Install the equipment in a location that meets the following conditions.

Environment	Conditions
Ambient Temperature	Operation: 15~35°C / Storage: -10~60°C (must not freeze)
Ambient Humidity	Operation & Storage: 30~85% RH (must not cause condensation)
Characteristics	Indoor (no direct sunlight), free from corrosive/flammable gases, with minimal dust and oil mist, no rapid temperature changes, free from strong vibration or shock, with sufficient ventilation, and with a flat and level floor.
Altitude	Below 1,000 m above sea level
Power Requirements	AC 220 V, 50~60 Hz, 5 A



- When transporting, at least two people should carry the equipment.
- Place the equipment down slowly to avoid shock.
- Use sufficient cushioning (air caps or Styrofoam) when transporting.
- Do not place the equipment horizontally.
- Warranty is valid only when rated cables are used.
- Replacement fuse specification for AC inlet: 250 VAC, T4AL.

3-2 Power and Communication Connections

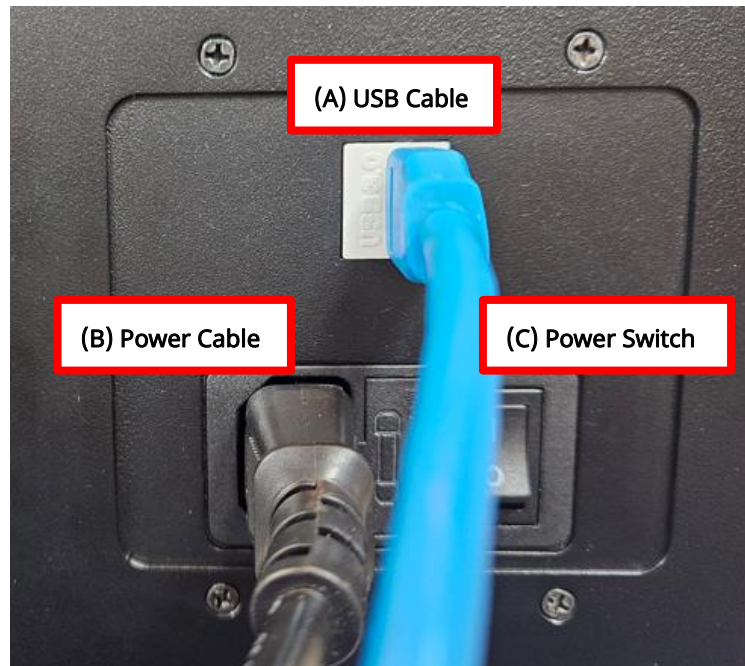

< Rear Connectors of Equipment >

Connect the equipment and PC in the following order.

- ① Make sure the power switch is turned off. "o" (off), "-" (on)
- ② Connect (A) USB cable and (B) power cable to their respective ports.
- ③ Connect the power cord to the power outlet.
- ④ Press (C) the power switch to supply power.
- ⑤ Check that the LED indicator on the equipment front panel and the LM Printer Driver on the PC are turned on.

The LM Printer Driver runs automatically when the equipment and PC are properly connected.





XLR-40 Series



- For personal and equipment safety, use a power cord suitable for the country/region of installation.
- Always turn off the equipment before connecting or disconnecting power and USB cables. Electrical damage or personal injury may occur.
- Do not operate the printer or power supply in a humid environment. Electrical damage or personal injury may occur.
- Do not connect input voltage outside the rated power supply specification. This may cause equipment damage or fire.
- For smooth operation, use the power and USB cables provided by the company. (USB 3.0 A to A cable of 1.8 m or shorter recommended)
- Do not bundle communication cables with objects that may cause electrical noise or electromagnetic interference. This may damage the equipment.

3-3 Media Installation (External Media Installation Appendix)

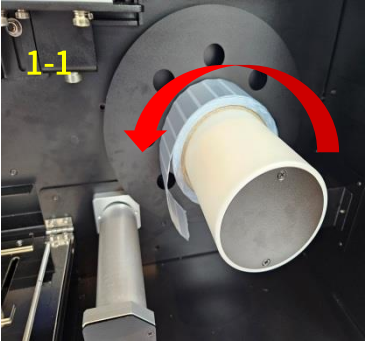
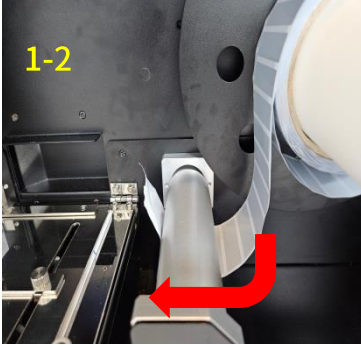
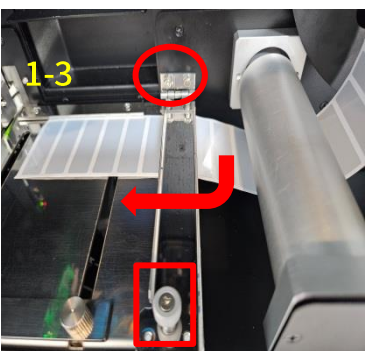
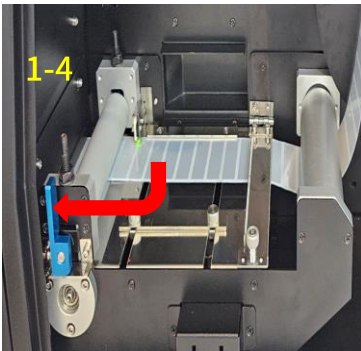
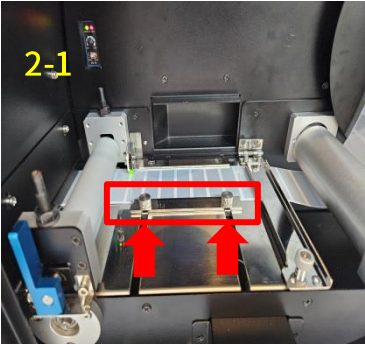
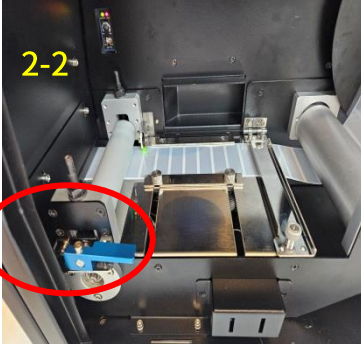
To maintain proper performance of this equipment, designated media must be used.

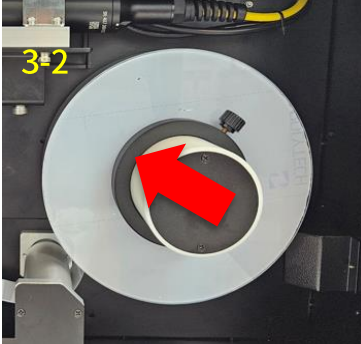
Image		Description	
 <p>1-1</p>	 <p>1-2</p>	<p>① Insert the media into the holder in the direction shown in the picture. If the media tension auxiliary guide shown in the photo 1-3 is bent excessively, the hinge part marked with a circle may be damaged. The screw section marked with a square should not be tightened but used as a handle.</p>	
 <p>1-3</p>	 <p>1-4</p>		
 <p>2-1</p>	 <p>2-2</p>		<p>② Insert the media into the gap of the Media Feeding Guide to prevent it from coming out during feeding, and then lower the Media Pressure Lever.</p>
 <p>3-1</p>	 <p>3-2</p>		<p>③ Tighten the screw of the Media Feeding Guide (3-1), then move the Media Roll Guide (3-2) so that it touches the media.</p>





- For safety, turn off the equipment when replacing media.
- Do not open the door cover while the equipment is operating.
- Open and close the door smoothly. Forcibly opening or closing the door may damage the equipment.
- Take care not to trap hands or tools when opening or closing the door.
- When replacing media, ensure that the door handle is fixed to the stopper on the top of the equipment. If the door is not fixed to the stopper, it may close suddenly.

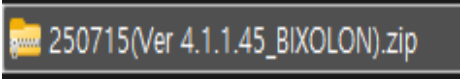

Do not overtighten the screws of the Media Feeding Guide or Media Roll Guide. This may hinder label feeding.

3-4 LM Driver Installation

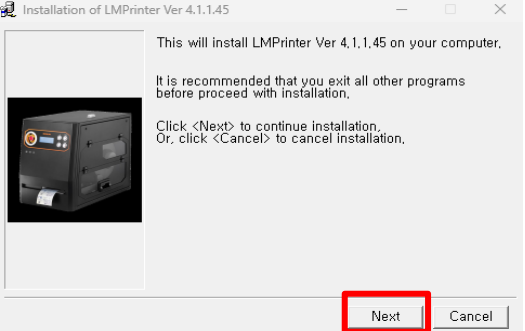
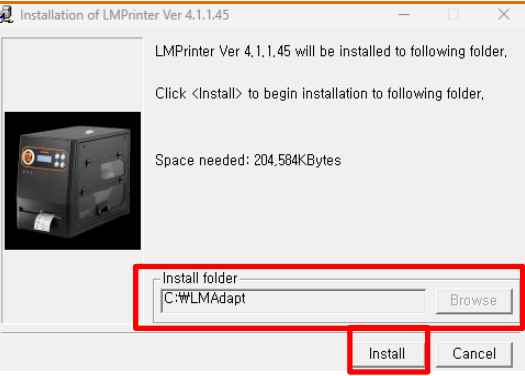
Image	Description
	<p>① Unzip the attached compressed file.</p>
	<p>② Install the driver in the following order.</p> <ul style="list-style-type: none"> -To install the driver → run driverinstall64.exe. -To uninstall the driver → run driveruninstall64.exe, then cleanup.exe, and reboot the PC. -To change the driver version → run Patch.exe in the PATCH folder. When reinstalling, uninstall the previous driver before installation.
	<p>③ Click Next.</p>
	<p>④ Set the installation path to the C drive and click Install.</p>

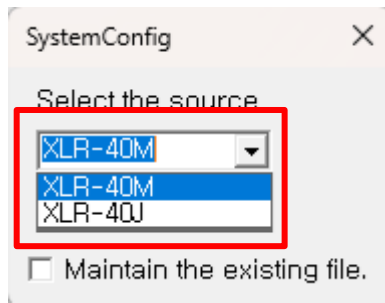



- ⑤ Select the equipment model name and click OK to complete installation.

- ⑥ After installing the software, connect the USB cable (Plug and Play) or turn the printer off and then on again. Then check that the driver is operating normally.

4. Printer Detailed Settings

4-1 Printer Setup Mode

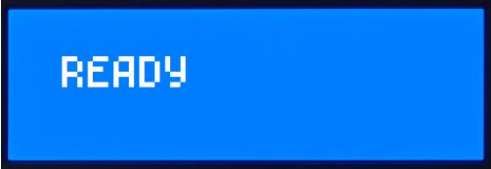

In setup mode, you can configure print quantity and media feeding speed.
Press Button 1 and the FEED button together for 2 seconds to enter setup mode.

LCD Screen	LCD Status	Description
	<p>You can change the number of media fed per print command.</p>	<p>Press Button 1 to decrease the value and Button 2 to increase it. Press Button 1 and the FEED button briefly at the same time to enter motor speed settings.</p>
	<p>Adjust the motor speed to change the media feeding speed. The larger the number, the faster the speed.</p>	<p>Press Button 1 to decrease the value and Button 2 to increase it. After completing the settings, press the FEED button to return to READY state.</p>
	<p>Once settings are saved, the system returns to READY state.</p>	<p>From the READY state, the printer can be used normally again.</p>

4-2 LM Driver

4-2-1 LM Driver Execution Sequence

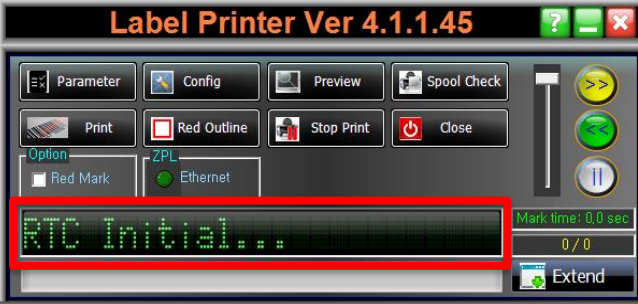
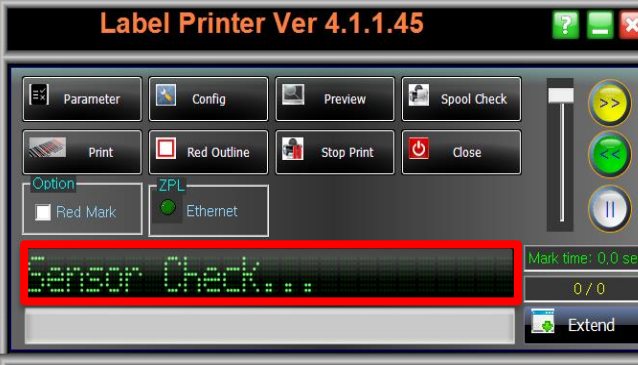
When the powered equipment and PC are connected via a USB cable, the driver runs automatically.

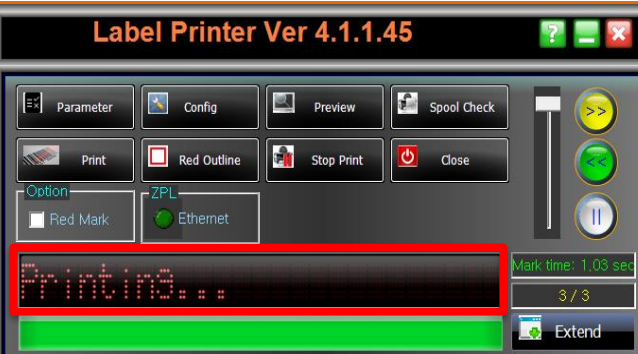

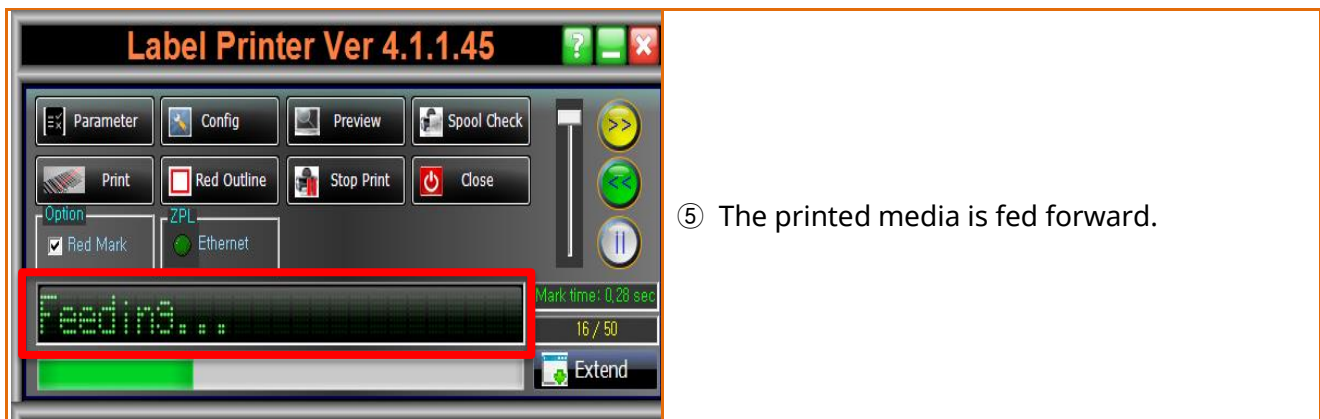

Image	Description
 <p>The screenshot shows the software interface for the Label Printer Ver 4.1.1.45. The status bar at the bottom displays 'RTC Initial...' in green text. The interface includes buttons for Parameter, Config, Preview, Spool Check, Print, Red Outline, Stop Print, and Close. There are also checkboxes for Red Mark, ZPL, and Ethernet. A progress bar and 'Mark time: 0.0 sec' are visible on the right side.</p>	<p>① After the driver starts, it prepares for operation.</p>
 <p>The screenshot shows the software interface for the Label Printer Ver 4.1.1.45. The status bar at the bottom displays 'Sensor Check...' in green text. The interface includes buttons for Parameter, Config, Preview, Spool Check, Print, Red Outline, Stop Print, and Close. There are also checkboxes for Red Mark, ZPL, and Ethernet. A progress bar and 'Mark time: 0.0 sec' are visible on the right side.</p>	<p>② The media position sensor adjusts the media to the correct position.</p>
 <p>The screenshot shows the software interface for the Label Printer Ver 4.1.1.45. The status bar at the bottom displays 'Ready...' in green text. The interface includes buttons for Parameter, Config, Preview, Spool Check, Print, Red Outline, Stop Print, and Close. There are also checkboxes for Red Mark, ZPL, and Ethernet. A progress bar and 'Mark time: 0.0 sec' are visible on the right side.</p>	<p>③ The equipment is now ready for operation.</p>
 <p>The screenshot shows the software interface for the Label Printer Ver 4.1.1.45. The status bar at the bottom displays 'Printing...' in green text. The interface includes buttons for Parameter, Config, Preview, Spool Check, Print, Red Outline, Stop Print, and Close. There are also checkboxes for Red Mark, ZPL, and Ethernet. A progress bar and 'Mark time: 1.03 sec' are visible on the right side.</p>	<p>④ The laser is emitted to print on the media.</p>



4-2-2 LM Detailed Description of LM Driver Functions

Summary of LM Driver Button Functions

Button	Description
Parameter	Allows setting laser and scanner speed, pulse, and power values.
Config	Allows configuring print settings such as coordinates, patterns, and density.
Preview	Allows previewing data before printing.
Print	Prints the data sent as a print command.
Red Outline	Checks the outline of the print area with the Red Beam (guide laser beam). Can be checked with the door open.
Stop Print	Stops the printing operation.
Spool Check	Deletes remaining spool data.
Close	Exit the driver.
Option <input checked="" type="checkbox"/> Red Mark	Checks the data to be printed using the Red Beam (guide laser beam).
	>>: Back Feeding (Media reverse feed) <<: Feeding (Media forward feed) : Stop
Extend	Expands the driver screen to check logs and I/O status.
Change User	Changes driver access permissions.

 Open	Loads saved configuration values.
 OK	Applies the specified values.
 Save As	Saves the current settings.
 Cancel	Cancels.



Parameters

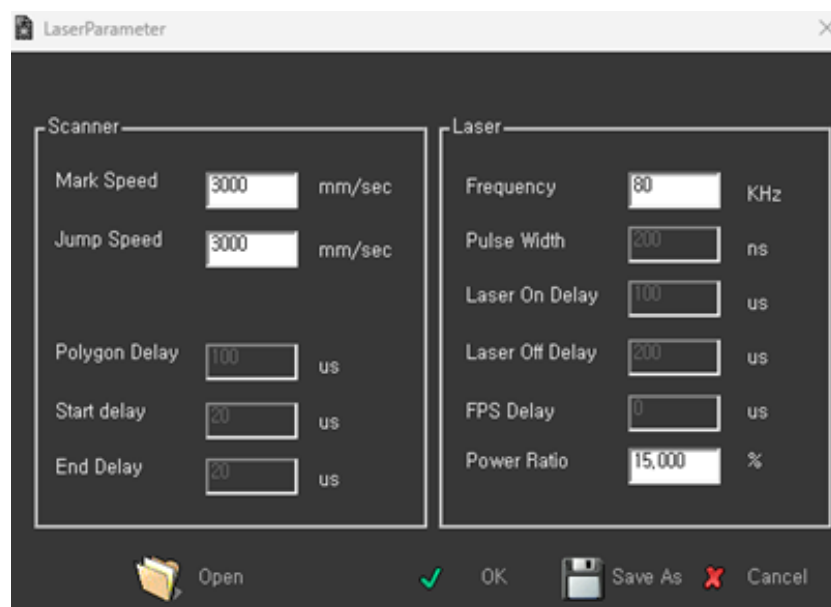

Functions	Description
Scanner	
Mark Speed	Sets the moving speed of the laser beam. The recommended value is 2,000~3,000 mm/s. Mark Speed is the speed during laser marking, and Jump Speed is the speed at which the laser moves to the marking point. If the value is too high, laser marking may not be properly applied.
Jump Speed	
Polygon Delay	Delay value when the scanner passes the corner of the print object.
Start delay	Delay before the laser turns on prior to starting the next object marking.
End Delay	Delay after object marking ends but before the laser turns off.

Laser	
Frequency	Sets the laser pulse frequency. For model XLR-40M: 10~80 kHz, recommended 60~80 kHz. For model XLR-40J: 10~600 kHz, recommended 200 kHz. If the value is too low, strong thermal energy may cause bubbling or burning of the media.
Pulse Width	Sets the duration of a single laser pulse emission.
Laser On Delay	Delay before the laser emission begins.
Laser Off Delay	Delay before the laser emission ends.
FPS Delay	Delay applied only to the first laser pulse.
Power Ratio	Sets the laser power. Adjustable between 0~100%. Recommended values: XLR-40M = 10%, XLR-40J = 15%.



Values outside the recommendation may cause media damage or affect print quality.



Settings (configuration)

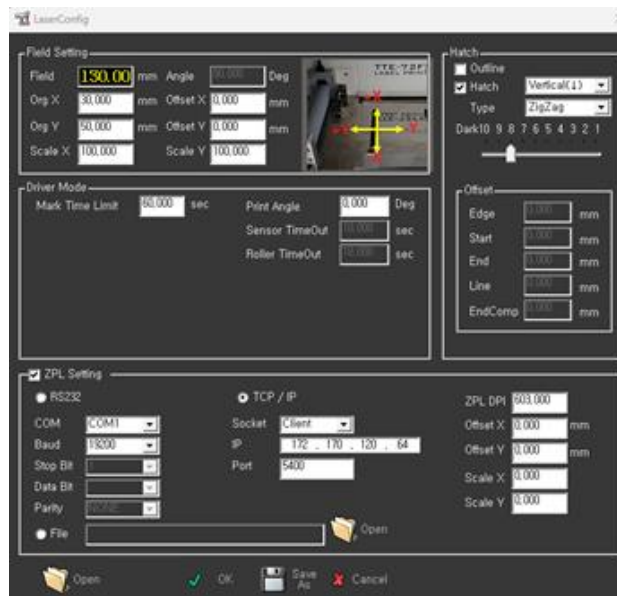

Functions	Description
Field Setting	
Field	Specifies the width and height of the scanner’s print area. Default value is 130 mm.
Org X, Org Y	Offset for setting the origin of the mechanism. Sets coordinate values for the scanner field. Coordinates can be adjusted in the arrow directions shown in the right-hand image.
Offset X, Offset Y	Sets the position coordinates of the print data. Adjust position using the arrows corresponding to Org X and Org Y in the image.
Scale X, Y	Specifies the scale of laser horizontal and vertical lines. Default value is 100. Adjust Scale X to change Y-axis size, or Scale Y to change X-axis size of the print data in the right-hand image. Increasing enlarges the size, decreasing reduces it.
Hatch	
Outline	When checked, outlines the print data for clearer printing.
Hatch	Fills the content area with laser marking. Allows selecting the direction and pattern of laser marking.
Dark (Hatch Distance)	Sets the hatch spacing of the laser. The larger the value, the narrower the spacing. Affects printing speed. Recommended value is 9-7.
Driver Mode	
Mark time limit	Limits the maximum laser emission time for safety. Stops laser emission when the set time is exceeded. Prevents the risk of continuous laser emission in emergencies.
Print angle	Allows rotation of print data.

ZPL Setting

When checked, communicates with the driver-installed PC to print ZPL data. You can set the communication method or place ZPL files in a designated folder for printing. Offset X,Y and Scale X,Y for ZPL can be set separately.

ZPL DPI

Sets DPI in the LM driver to match DPI included in ZPL commands.



Generally, Org X,Y and Offset X,Y perform the same function of adjusting laser emission position.

Preview **Preview**

Allows you to view the print data entered in the driver in detail or load a scale pattern to perform a scanner origin test.

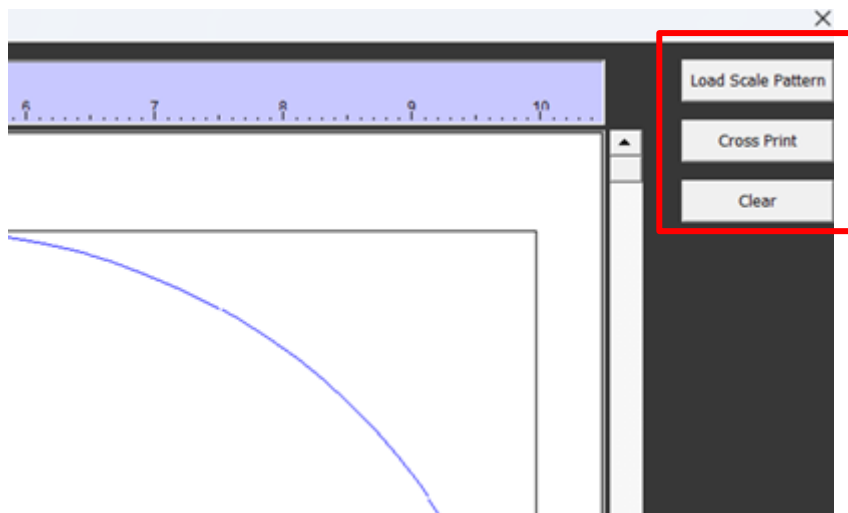

Functions	Description
Load Scale Pattern	Loads an image for scanner origin testing.
Cross Print	Emits a cross-shaped laser at the scanner's central coordinates. The door must be closed during testing.
Clear	Deletes the image.



Red Mark + Print

When Red Mark is checked and Print is pressed, the guide beam confirms the position of the actual print data. Can be checked with the door open.

(The XLR-40J model does not support the guide beam function.)

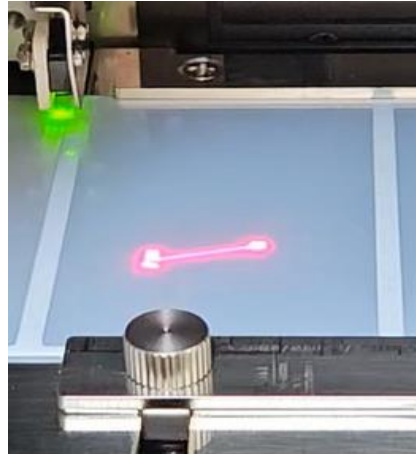

< Image showing print position check >



Print

Prints the data.

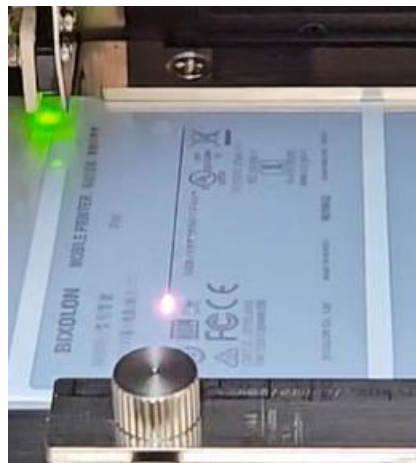

< Image of printing with laser >

Red Outline Red Outline

Allows checking the print area with the guide beam.
(The XLR-40J model does not support the guide beam function.)

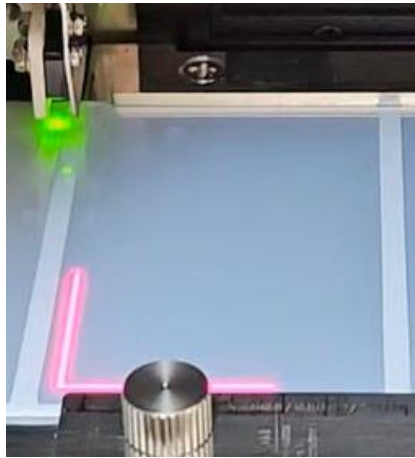

< Image showing outline alignment within media >



Always check the print position with the Red Outline before printing. The red guide beam can be viewed with the door open.

Stop Print Stop Print

Stops the emission of the laser or guide beam.

Spool Check Spool Check

Allows you to decide whether to delete spool data.
Pressing Yes deletes spool data, while No continues printing the remaining spool data.

Close Exit

Exit the driver.



Expand Window

Allows you to check print data, I/O status, and log data.

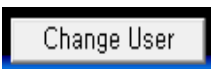
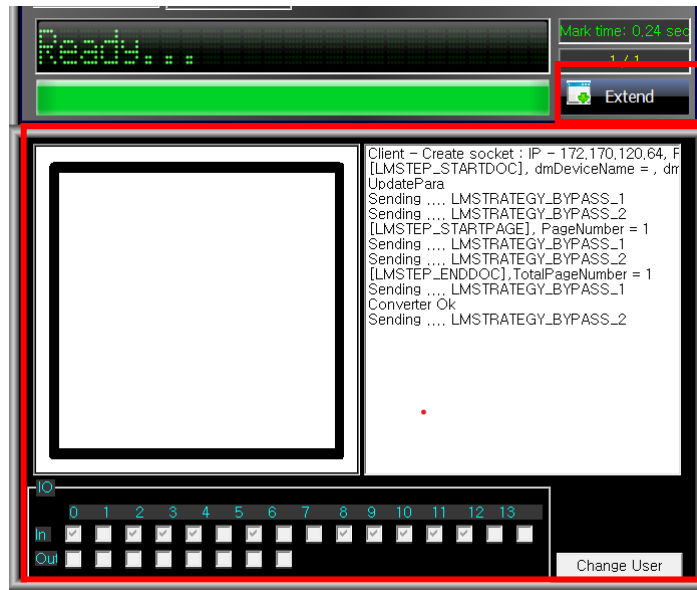

User Switch

Changes driver access permissions. Only Operator-level access is allowed for general users. The Operator password is 0000.

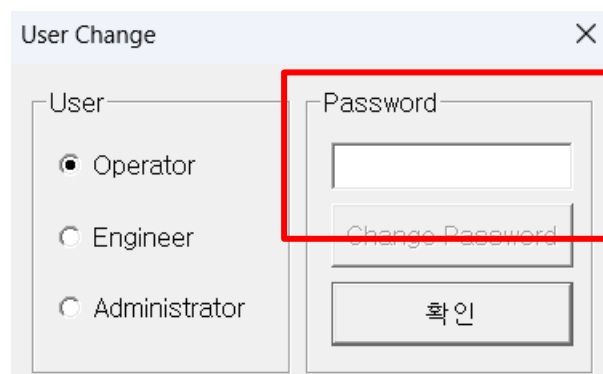

4-2-3 Adding Media Size

Adds a new media size. Open the printing preferences window using the following path:
 Start → Settings → Devices → Printers & Scanners → LM Printer → Manage → Printing Preferences

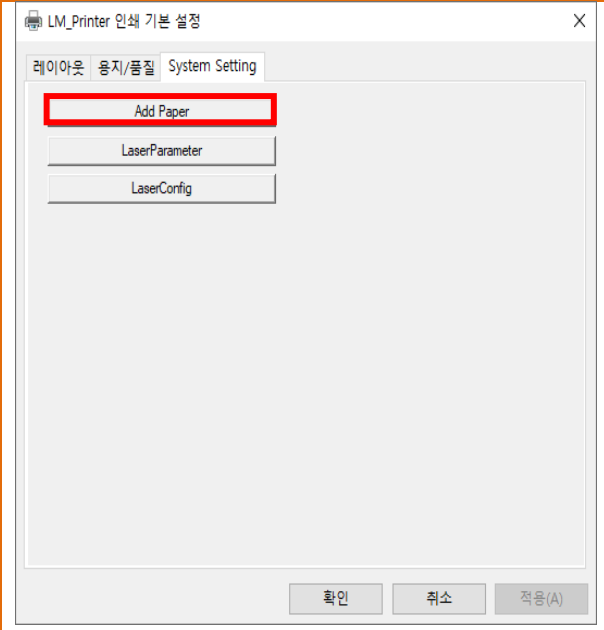
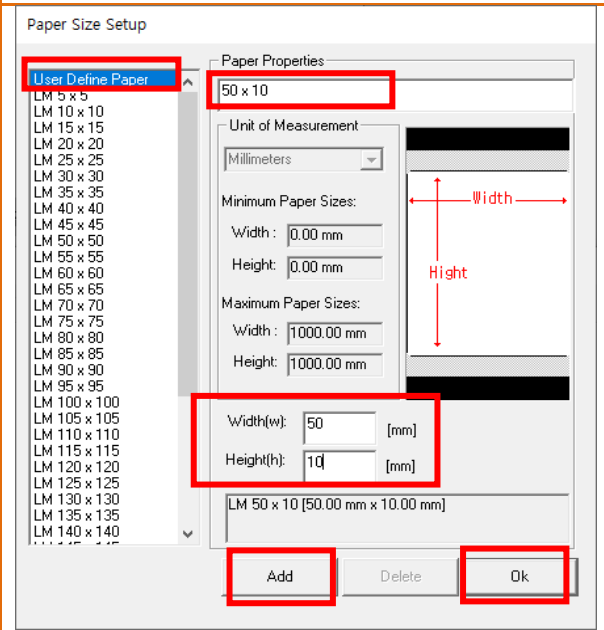
Image	Description
	<p>① In System Setting, click Add Paper.</p>
	<p>② Enter the media items to add. Paper Properties: Media Name Width: Media Width Height: Media Height *Be sure to click Add first, then OK to register.</p>

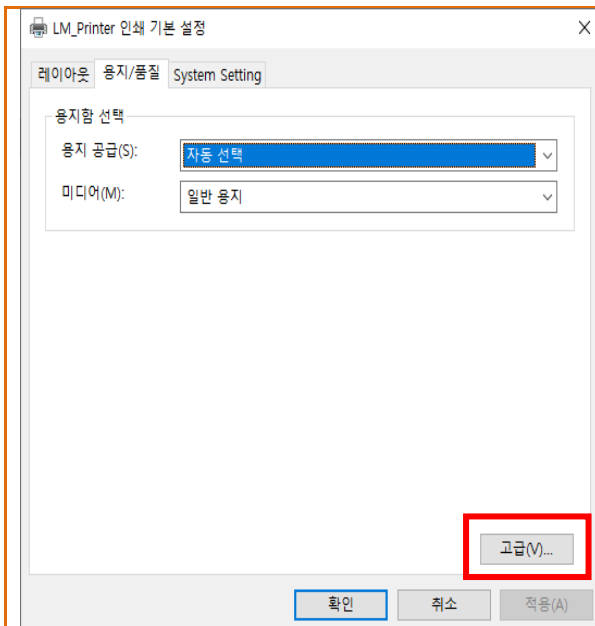

③ In Printing Preferences → Paper/Quality tab, click “Advanced”.

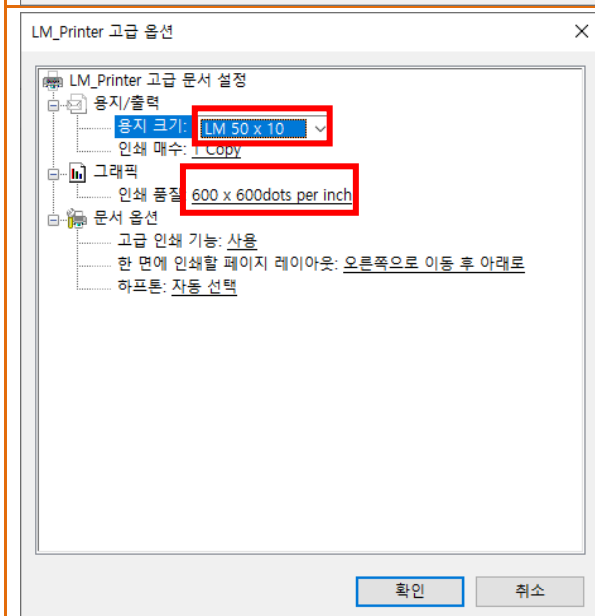

④ Load the settings for the added media.
If not applied, close and reopen the settings window.

In Graphics - Print Quality, resolution can be set between 600 and 2,000 dpi. The higher the resolution, the slower the print speed.

5. Equipment Maintenance

5-1 Maintenance and Inspection Methods

Item	Inspection Interval	Maintenance and Inspection Methods
Laser Label Printer	Always	<ul style="list-style-type: none"> - Always turn off power using the rear power switch of the equipment. Continuously using the Emergency Switch to cut power may shorten the laser lifespan and affect the equipment. - A dust collector is required when using media that generates dust. When cleaning, turn on the dust collector, remove foreign substances with a dry cloth, and wipe the interior carefully.
Roller	Weekly	<ul style="list-style-type: none"> - If contamination is visible, clean with wet wipes, then remove moisture with a dry cloth.
F-Theta Lens	Weekly	<ul style="list-style-type: none"> - Use a clean mirror to check for contamination. <p>If contaminated, clean according to the scanner lens cleaning instructions in the manual.</p>

5-2 Scanner Lens Cleaning Method

If print quality deteriorates, contamination of the scanner lens should be suspected. The scanner lens can be cleaned as follows:

Image	Description
	<p>① Prepare a hand blower (1-1), lens cleaner (1-2), and cleaning paper (1-3) as shown.</p>
	<p>② Rotate the scanner lens counterclockwise to remove it.</p>
	<p>③ Hold the lens carefully without touching both glass surfaces and blow away dust with the hand blower.</p>
	<p>④ Spray lens cleaner on the cleaning paper and gently wipe the lens.</p>

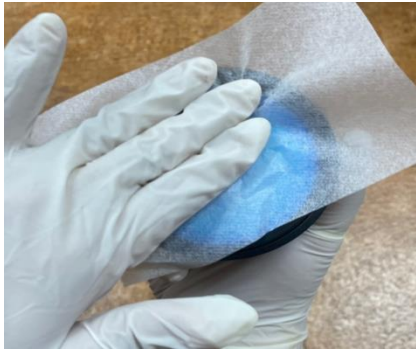

⑤ Wipe once more with new cleaning paper.

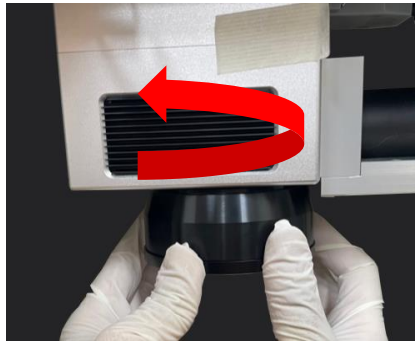

⑥ Reassemble the scanner lens, paying attention to the threads. It must be properly aligned with the threads when reassembled.



- If any lens cleaner or alcohol remains on the lens surface, it may pose a fire risk during operation. Ensure it is clean before reassembling the scanner.
- For normal laser operation, the scanner must be correctly reassembled according to the screw threads. Forcing the scanner into place may damage the threads and render it unusable.

6. Troubleshooting

6-1 Symptoms and Countermeasures

If you encounter symptoms that appear to be malfunctions, check the following items. If the issue is not resolved, contact your dealer.





Symptom	Countermeasure	Reference Manual Section
Power does not turn on.	① Check that the power cable is connected correctly.	3-2
	② Check whether the emergency stop button is pressed.	2-1-1
LCD screen does not turn on or malfunctions.	① Reboot the equipment.	-
LM driver does not run or shows an error message.	① Check that the USB cable is connected properly.	3-2
	② Check that the driver is installed correctly.	3-4, 6-2-3
Laser does not emit.	① Check if the lens cover is attached to the scanner head.	2-2
	② Check the status on the equipment LCD/LED.	2-1-2, 2-1-3
	③ Check whether data is sent to the preview window. (If sent, check the laser coordinates.)	4-2-2
Print quality is poor.	① Check whether parameter and config settings are as specified at shipment.	4-2-2
	② Check for lens contamination.	5-1, 5-2

XLR-40 Series

Media does not feed.	① Check whether the pressure lever is lowered.	3-3
Media does not stop at the correct position during feeding.	① Adjust the sensitivity of the gap sensor.	6-2-1
Noise from the motor/roller during feeding, or weak roller pressure.	① Contact your dealer.	-
Media deviates from the path during feeding.	① Mount the media correctly.	3-3
	② Roller pressure is not evenly distributed on the media. Adjust so that roller pressure is applied evenly.	6-2-2

6-2 Detailed Countermeasures

6-2-1 Sensor Amplifier Sensitivity Adjustment

Image	Description
	<p>① Locate the sensor amplifier.</p>
	<p>② Adjust sensitivity using the amplifier screw. Use a flathead screwdriver to make fine adjustments in 1/5 turns.</p>
	<p>③ Turning to the right (MAX) increases gap detection sensitivity.</p>
	<p>④ Turning to the left MIN decreases gap detection sensitivity.</p>

6-2-2 Roller Pressure Adjustment

If roller pressure is uneven, media may shift toward the side with greater pressure. In such cases, adjust roller pressure evenly.

Photo and Description

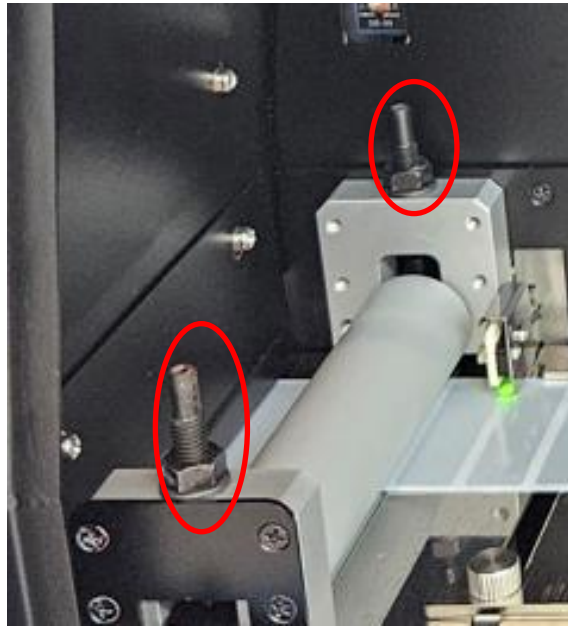

The part shown in the photo is the roller pressure adjustment knob. Use a wrench to tighten or loosen the knobs so that both apply equal and proper pressure to the roller. Turning clockwise increases pressure, and counterclockwise decreases it.

6-2-3 How to Check Normal Installation of LM Driver

If the LM driver does not operate normally, check the following:

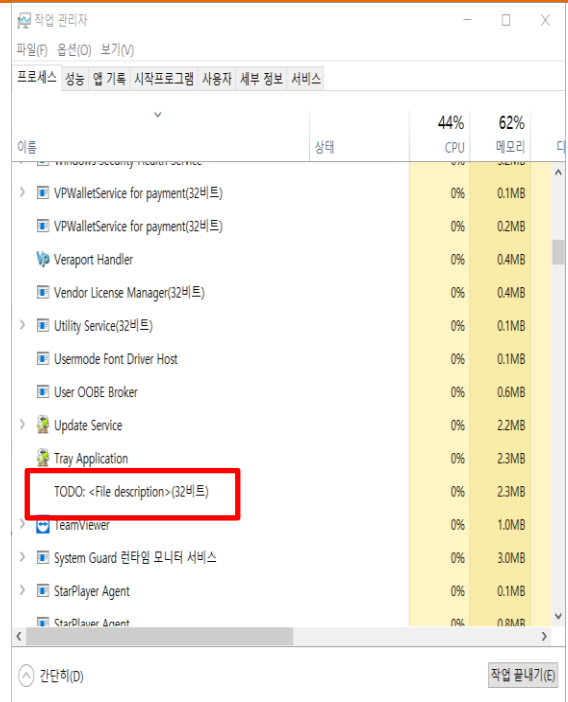
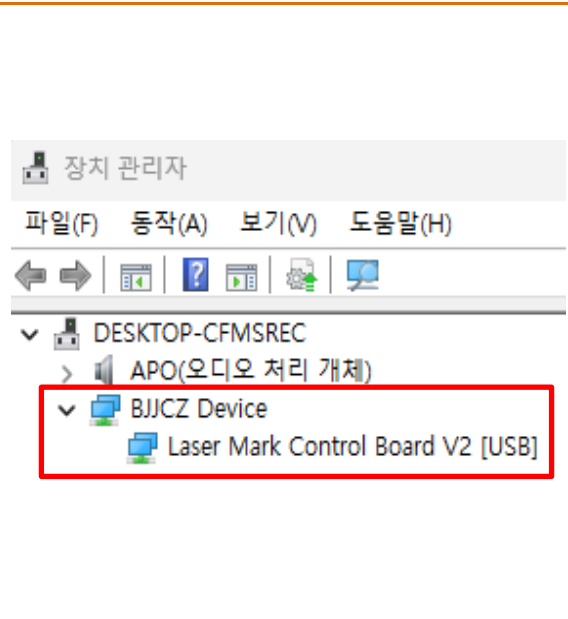
Image	Description
 <p>A screenshot of the Windows Task Manager window. The 'Processes' tab is selected. A list of processes is shown with columns for '이름' (Name), '상태' (Status), 'CPU', and '메모리' (Memory). The process 'TODO: <file description> (32비트)' is highlighted with a red rectangular box.</p>	<p>① When the LM driver is running, check Task Manager → Processes → Todo<file description>. If not, reboot the driver and PC to check again.</p>
 <p>A screenshot of the Windows Device Manager window. The 'DESKTOP-CFMSREC' device is expanded, showing 'APO(오디오 처리 개체)' and 'BJJCZ Device'. Under 'BJJCZ Device', 'Laser Mark Control Board V2 [USB]' is listed and highlighted with a red rectangular box.</p>	<p>② In Device Manager, check if the BJJCZ device is properly installed and recognized. If not recognized, reinstall the LM driver. If the issue persists, contact your dealer.</p>

7. Appendix

7-1 External Views

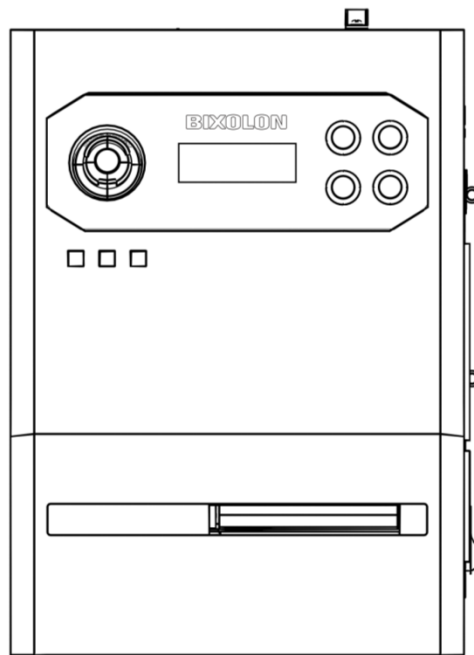

< Front >

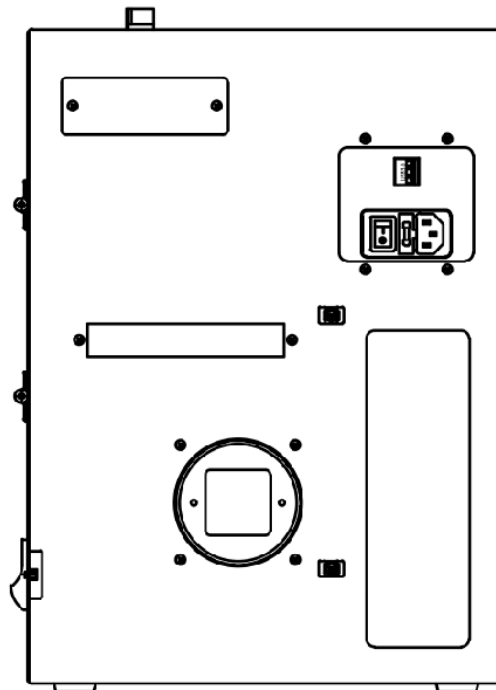

< Rear >

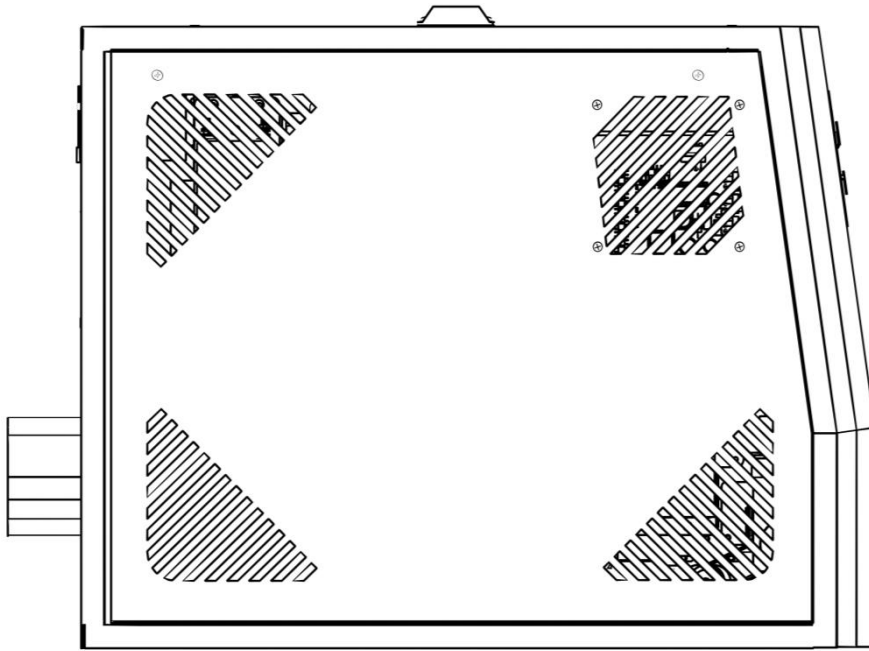

< Left Side >

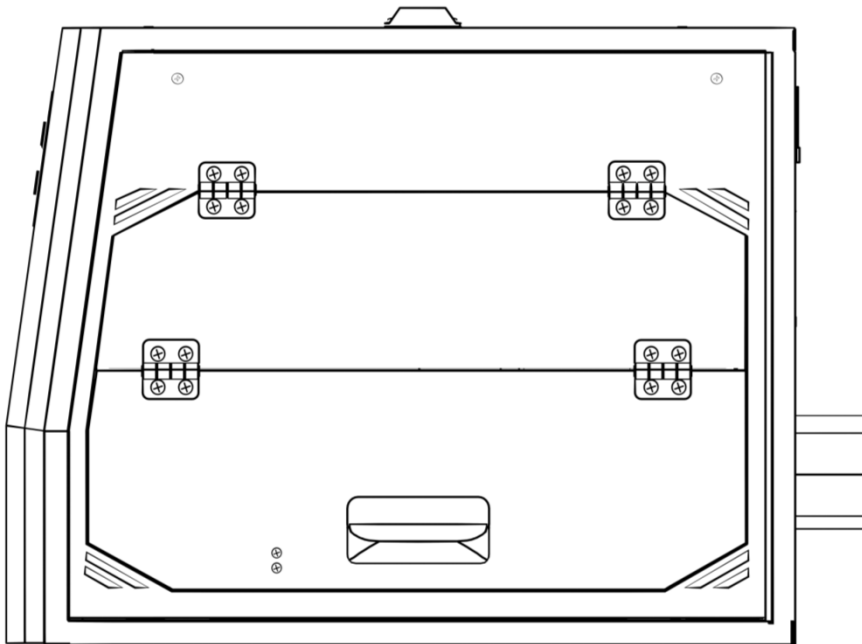

< Right Side >

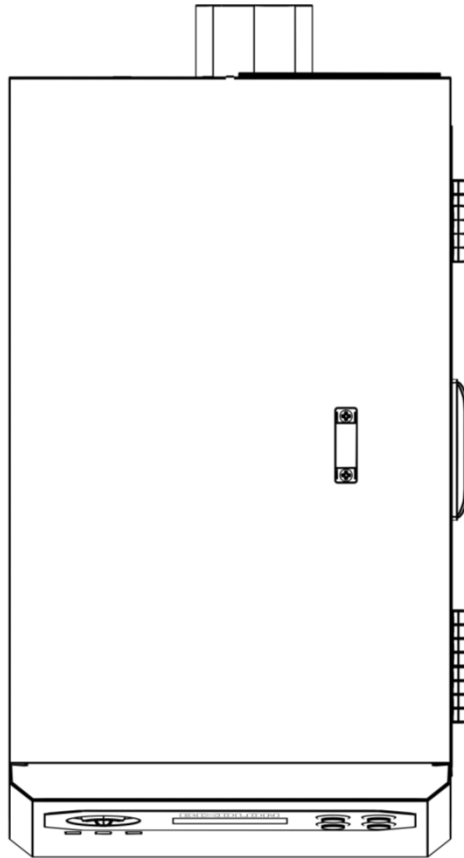

< Top >

