

**BIXOLON®**

**User's Manual**

**BK5-41**

---

**KIOSK PRINTER**

**Ver. 1.01**

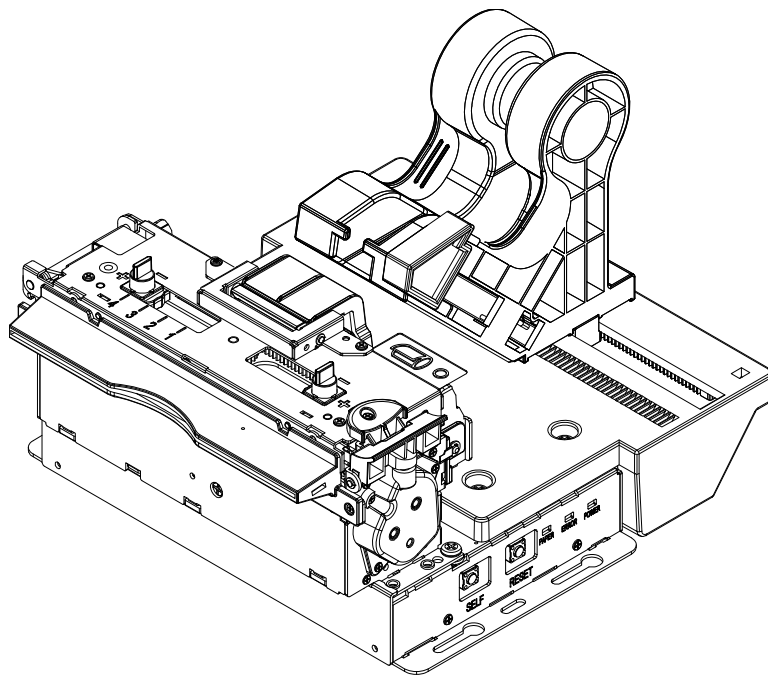

[www.bixolon.com](http://www.bixolon.com)

## Copyright

© BIXOLON Co., Ltd. All rights reserved.

This user manual and all property of the product are protected under copyright law. It is strictly prohibited to copy, store, and transmit the whole or any part of the manual and any property of the product without the prior written approval of BIXOLON Co., Ltd. The information contained herein is designed only for use with this BIXOLON product. BIXOLON is not responsible for any direct or indirect damages, arising from or related to use of this information.

- The BIXOLON logo is the registered trademark of BIXOLON Co., Ltd.
- All other brand or product names are trademarks of their respective companies or organizations.

BIXOLON Co., Ltd. maintains ongoing efforts to enhance and upgrade the functions and quality of all our products.

In the following, product specifications and/or user manual content may be changed without prior notice.

## Caution

Some semiconductor devices are easily damaged by static electricity. You should turn the printer "OFF", before you connect or remove the cables on the rear side, in order to guard the printer against the static electricity. If the printer is damaged by the static electricity, you should turn the printer "OFF".

## Compliance information

This device complies with Part 15 of the FCC Rules. Operation is subject to the following two conditions: (1) This device may not cause harmful interference, and (2) This device must accept any interference received, including interference that may cause undesired operation.

This equipment has been tested and found to comply with the limits for a Class A digital device pursuant to Part 15 of the FCC Rules. These limits are designed to provide reasonable protection against harmful interference when the equipment is operated in a commercial environment. This equipment generates uses, and can radiate radio frequency energy and, if not installed and used in accordance with the instruction manual, may cause harmful interference to radio communications. Operation of this equipment in a residential area is likely to cause harmful interference in which case the user will be required to correct the interference at his own expense.

Caution: Exposure to Radio Frequency Radiation.

To comply with FCC RF exposure compliance requirements, a separation distance of at least 20 cm must be maintained between the antenna of this device and all persons.

Caution: Any Changes or modifications not expressly approved by the manufacturer could void the user's authority to operate the equipment.

Class A Digital Device : Wired Device

This Apparatus complies with class "A" limits for radio interference as specified in the Canadian department of communications radio interference regulations.

This Class A digital apparatus complies with Canadian ICES-003.

Appareil numérique de classe A: appareil filaire

Get appareil est conforme aux normes class "A" d'interference radio tel que specifier par ministre canadien des communications dans les reglements d'interference radio.

Cet appareil numérique de la classe A est conform à la norme NMB-003 du Canada.

## **Waste Electrical and Electric Equipment (WEEE)**

This marking shown on the product or its literature, indicates that it should not be disposed with other household wastes at the end of its working life. To prevent possible harm to the environment or human health from uncontrolled waste disposal, please separate this from other types of wastes and recycle it responsibly to promote the sustainable reuse of material resources. Household users should contact either the retailer where they purchased this product, or their local government office, for details of where and how they can take this item for environmentally safe recycling. Business users should contact their supplier and check the terms and conditions of the purchase contract. This product should not be mixed with other commercial wastes for disposal.



## WARNING & CAUTION

Is described as death, physical injuries, serious financial losses, and damage to data etc. that can be caused to the user.

Do not connect multiple products to a single or faulty power outlet. Use only grounded power outlets that meet the industry standard. **Noncompliance may cause electric shock or fire.**



Only use authentic products from BIXOLON. The company will not provide post-sale support for damaged or other quality issues that any fake (or refurbished) products may incur.

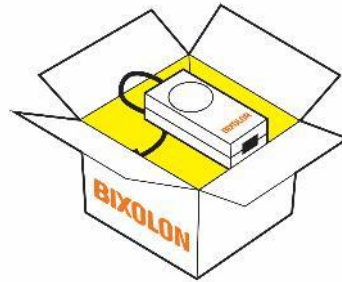

Do not excessively bend or strain the power cord. Securely push the power cord all the way into the power outlet lest it remain loose. Make sure to hold the cord tight when separating it from the power outlet. Do not remove the power cord while the product is in use. **Noncompliance may cause electric shock or fire.**

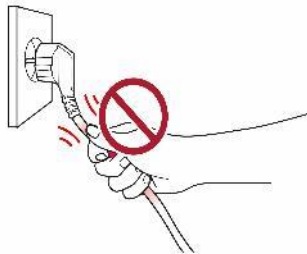

Keep small accessories or other packaging materials away from young children. Beware: choking hazard. **Mishandling the product may incur injuries which may require seeking urgent medical attention.**

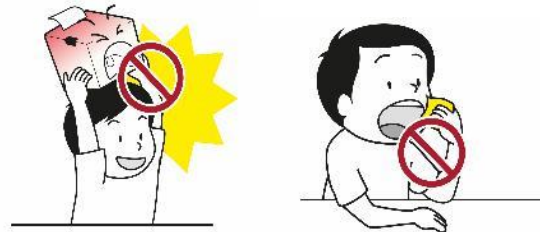

Keep excessive liquids away from the power cord and outlet. If matter is smeared onto the power cords, wipe with a dry cloth. **Noncompliance may cause electric shock or fire.**

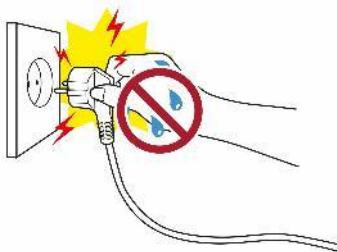

Do not allow the product to be damaged by heavy objects. **Noncompliance may cause electric shock or fire.**



If the product emits a strange sound, burning smell, or smoke, turn off the power immediately and unplug the power cord. If the product is dropped or its exterior is damaged, turn off the power immediately and unplug the power cord. Do not subject the product to shock. **It may start a fire. It may damage the product.**

Install the product in a well-ventilated area by keeping it a certain distance from the wall. The product installed in certain places such as where a lot of fine dust is generated, where the temperature is too high or too low, where there is a lot of moisture or water, and at airports or stations that are used continuously for a long time may suffer serious quality problems due to the influence of the surrounding environment. **An increase in internal temperature may start a fire. Be sure to contact the place of purchase before installing the product.**

Install the product in a fixed place preventing it from tipping over. When moving the product, turn off the power and disconnect all connected cables, including the power cord. **It may damage the product.**

Never independently disassemble, repair, or modify the product as the warranty will become invalid. **When repair is necessary, contact the original place of purchase.**

Do not let any foreign substances enter the product. Do not place heavy objects, liquids, or metals on the product. **This could cause damage to the product or a fire.**

If there is a problem with the product, please contact the original place of purchase or through BIXOLON website's product repair page (<http://www.bixelon.com>).

## Manual Introduction

This manual provides basic information on printers and provides ways to install, use, and check them. In order to protect the safety of users and prevent property damage, be fully familiar with this manual before using the product. Please use it.

## Manual Symbol Introduction



Precaution &  
Warning





It describes death, physical injuries, serious financial losses, and damage to data etc. that can be caused to the user.



Note

It provides additional information on the function and performance of the product.

## Product Symbol Introduction

	DC (Direct current)
	Error, Warning
	Paper Feeding
	Stand-By
	USB

## **Printer Introduction**

BK5-41 printers have been designed to be connected to various types of kiosk system.

### **The main features of the printer are as follows**

1. KIOSK PRINTER
2. Thermal Receipt Printer
3. Maximum 150mm/s printing speed
4. External size
  - Diameter  $\Phi$  130: 167 x 168 x 124 (W x D x H)
5. Serial/USB communication
6. Equipped with data buffer (receives print data even while printing)
7. Can print a range of barcodes
8. Range of printing density selectable  
(controlled with virtual memory switch management)

# Table of Contents

Copyright .....	2
WARNING & CAUTION .....	5
Manual Introduction .....	7
Printer Introduction .....	8
<b>1. Content Confirmation .....</b>	<b>11</b>
<b>2. Product Part Names .....</b>	<b>12</b>
2-1 Printer Names .....	12
2-2 Interface Part Names .....	13
<b>3. Installation &amp; Usage .....</b>	<b>14</b>
3-1 Printer Installation Placings .....	14
3-2 Power Connection .....	14
3-3 Adjust Paper Width .....	16
3-4 Inserting the paper roll .....	18
3-5 Adjust the Black Mark Sensor's Position .....	20
3-6 Using Controller .....	21
<b>4. Printer Setting Change .....</b>	<b>22</b>
4-1 Set Virtual Memory Switch .....	22
4-2 PAPER/ERROR LED Response Pattern .....	35
<b>5. Self-Test .....</b>	<b>36</b>
<b>6. Black Mark (Gap) Sensor Auto-Calibration .....</b>	<b>40</b>
<b>7. Product Specifications .....</b>	<b>41</b>
7-1 Set Serial number Classification .....	41
7-2 Printer Classification .....	41
7-3 Printer Specification .....	42
7-4 Paper Specification .....	44
7-5 Kiosk system specifications .....	45
7-6 Outer dimensions .....	46
7-7 Communication and Port Specification .....	48
7-7-1 Interface Specifications .....	48
7-7-2 Port Specification -1 .....	49
<b>8. Hardware(Wiring Diagram) .....</b>	<b>50</b>
<b>9. Maintenance .....</b>	<b>51</b>
9-1 Paper Jam .....	51
9-2 Cleaning Printer .....	52
<b>10. Troubleshooting .....</b>	<b>53</b>
10-1 Troubleshooting flow chart .....	53
10-2 (A)POWER LED does not light .....	54
10-3 (B)PAPER and ERROR LEDs blink .....	55
10-4 (C)PAPER and ERROR LEDs lit .....	56
10-5 (D)PAPER LED lit .....	57

10-6 (F)ERROR LED lit..... 58  
10-7 (G)Self test is not printed ..... 59  
10-8 (H)Data from host is not printed normally ..... 60  
10-9 Power Problem ..... 61  
    10-9-1 Printing Quality Problems..... 62  
    10-9-2 Mechanism Problems ..... 63  
    10-9-3 Auto Cut Mechanism Problems..... 64

# 1. Content Confirmation



- If there is any part missing, please contact the place of purchase.
- The actual part may look different from the image.

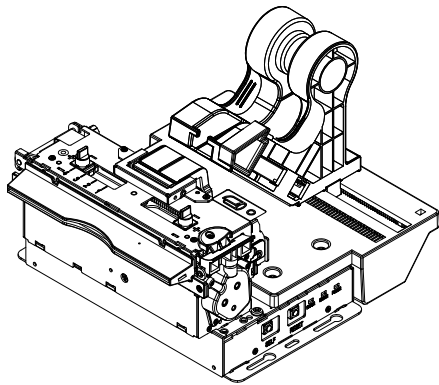

BK5L-41

**Option Components**

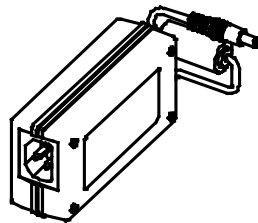

AC/DC Adapter(DC-Jack)

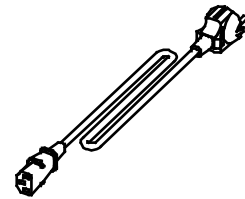

Power Cord

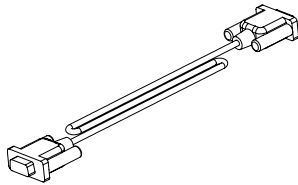

Serial Cable  
(Dsub 9pin - Dsub 9pin)

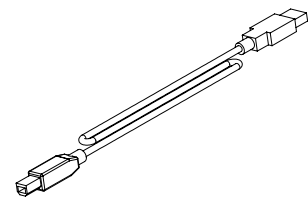

USB A-B Cable

## 2. Product Part Names

### 2-1 Printer Names

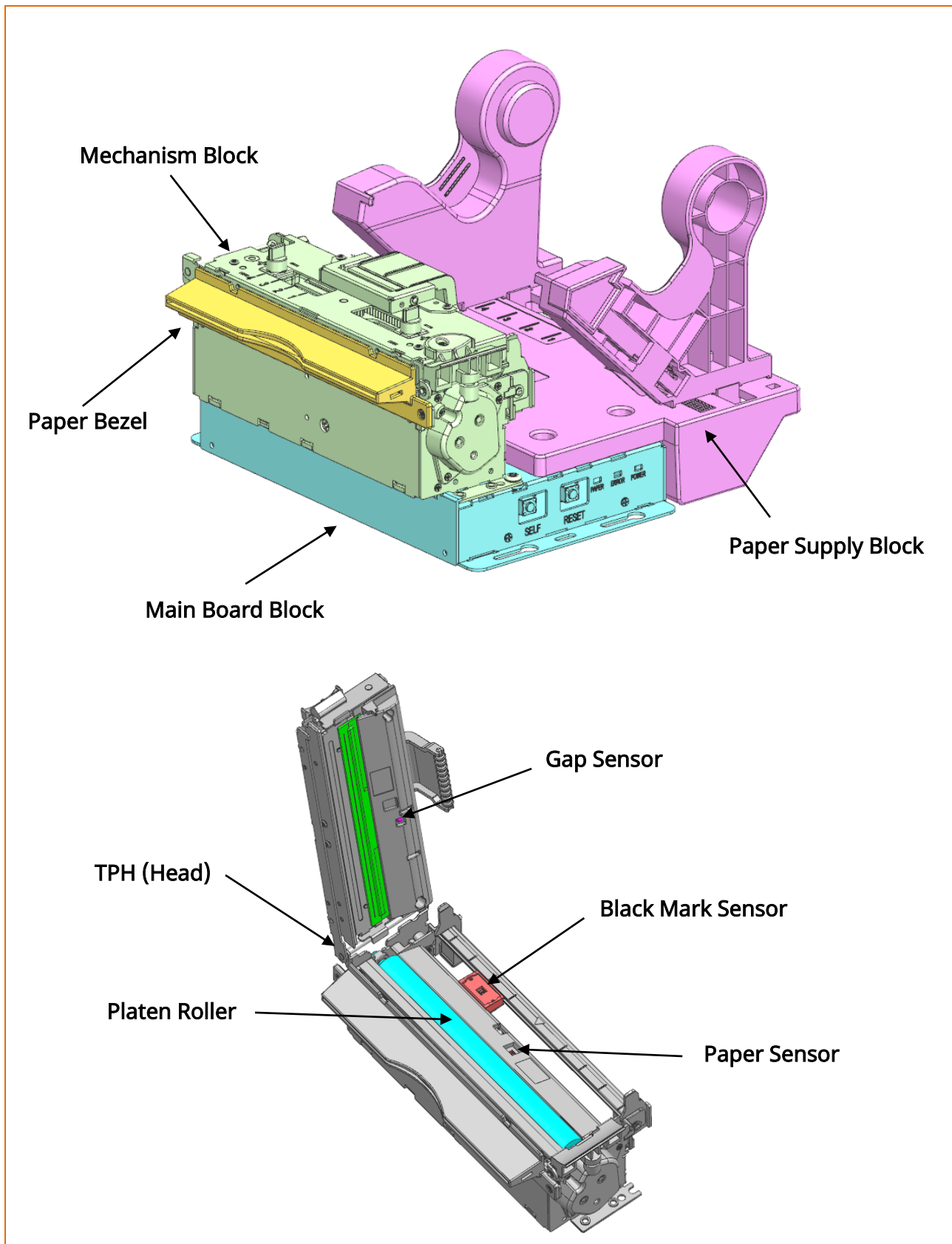

**2-2 Interface Part Names**

- Connect the printer to the host computer using the right interface cable that complies with the specifications of the interface.

BK5-41a Model: Serial Dsub 9P + USB B + DC Jack Power

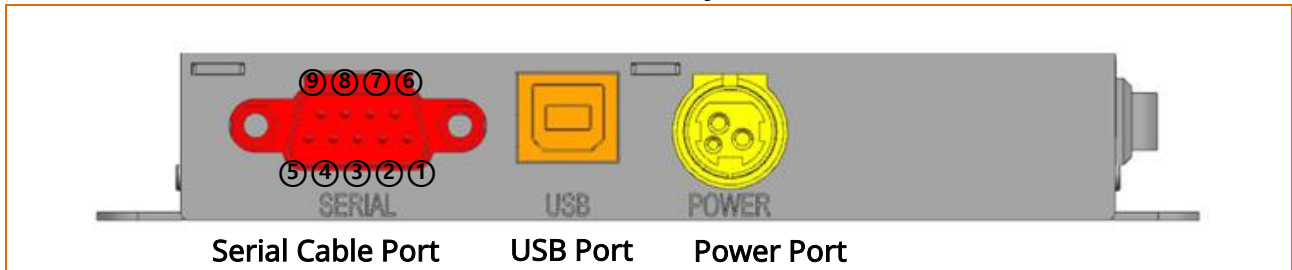

**Connect or disconnect the communication cable while the printer power is off. If power is on, your data may be lost**

## 3. Installation & Usage

### 3-1 Printer Installation Placings

- Install the printer in a well-ventilated area.
- Avoid humid environment.
- Do not place objects close to the back or bottom of the printer, which may hinder the air circulation.
- Install the printer on a flat and level surface.



- Install the printer on a flat surface without any slope.
- We are not liable for any issues related to product performance or quality.

- For precautions during product installation, please refer to Section 7-5, Kiosk System Specifications.

### 3-2 Power Connection

- Face the flat side of the power cable to the bottom of the printer and connect the power cable to the power port.

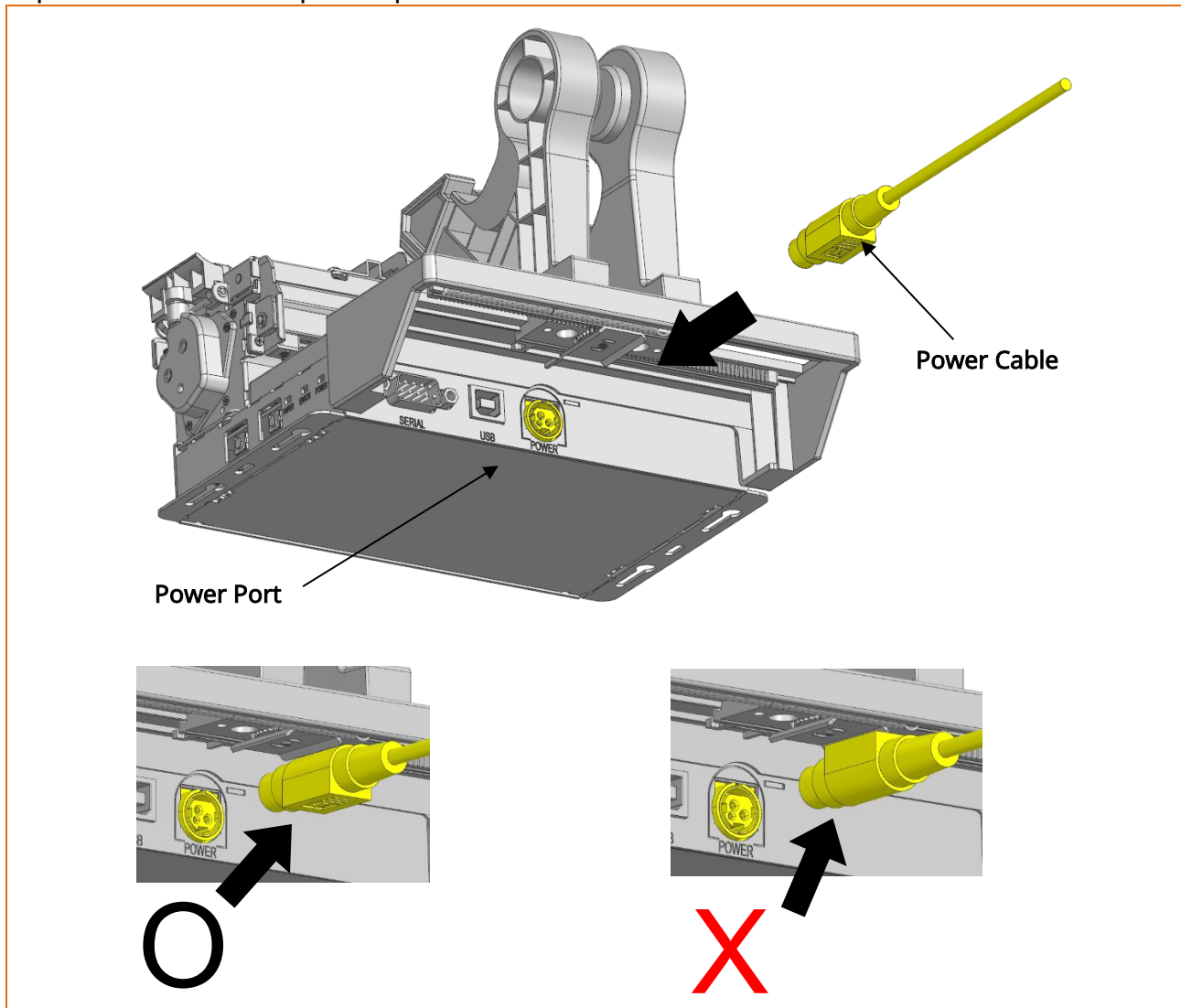

- Only use a power supply provided by Bixelon. Bixelon shall bear no responsibility for damage caused by using a third-party power supply.
- Check the power supply's label to check its electronic specs.
- When removing the power supply, make sure you have a firm grasp of the plug terminal of the power cable and the printer and pull horizontally.
- When connecting or disconnecting power, make sure to remove the power supply from the power outlet before removing.
- Pay attention to the direction in which you insert the power cord.
- Do not connect a voltage out of the specifications of the power supply. It can cause damage to the product or a fire.

**3-3 Adjust Paper Width**

- 1) Confirm the paper width that will be used (1inch ~ 4inch)
- 2) Adjust the Holder Paper to fit the paper specification

**\* Roll Type Paper**

- Simply spread the Holder Paper open on both sides and insert the paper, it will automatically lock into place. (spring)

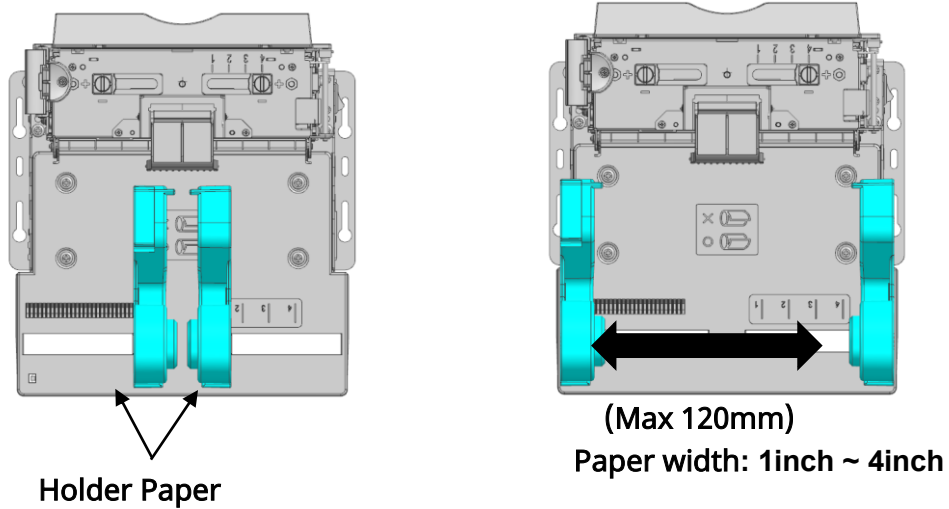

**\* Fanfold Type Paper**

- Spread the Holder Paper apart on both sides and press the Lock component into the desired position to secure it.

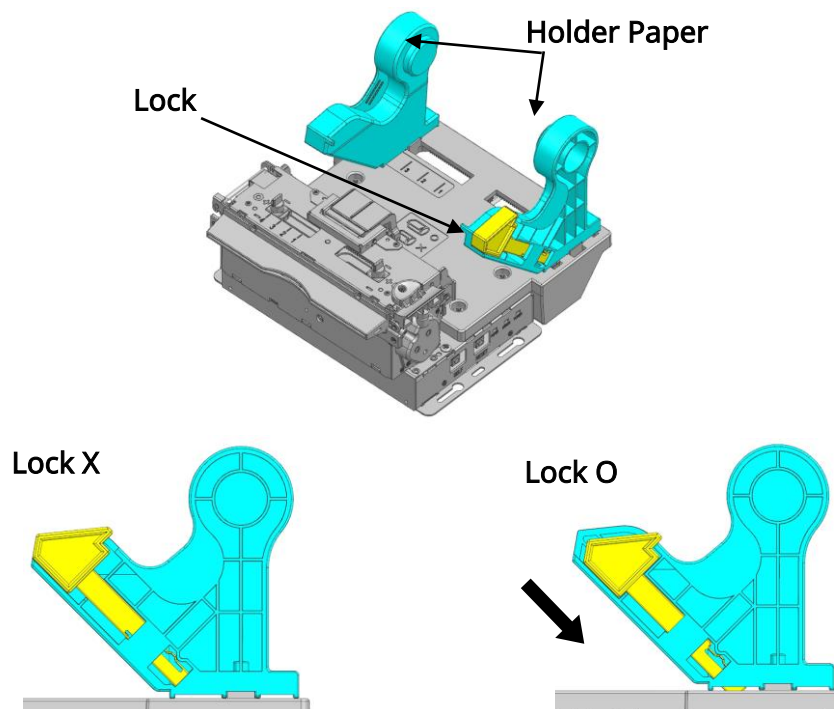

3) Adjust Guide-Paper L and R to fit the paper width.

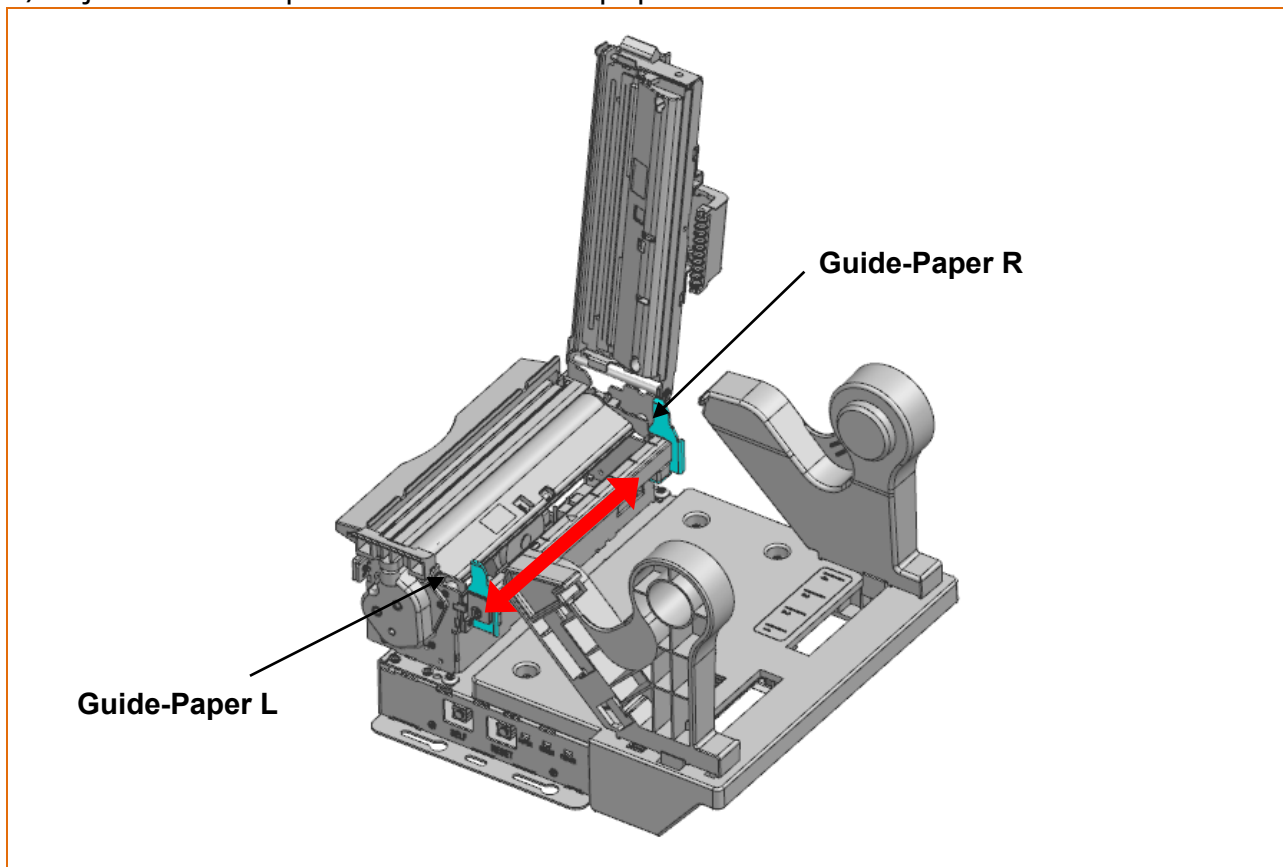

3-4 Inserting the paper roll

1) Push the Lever-Lock to open the printer Thermal head cover.

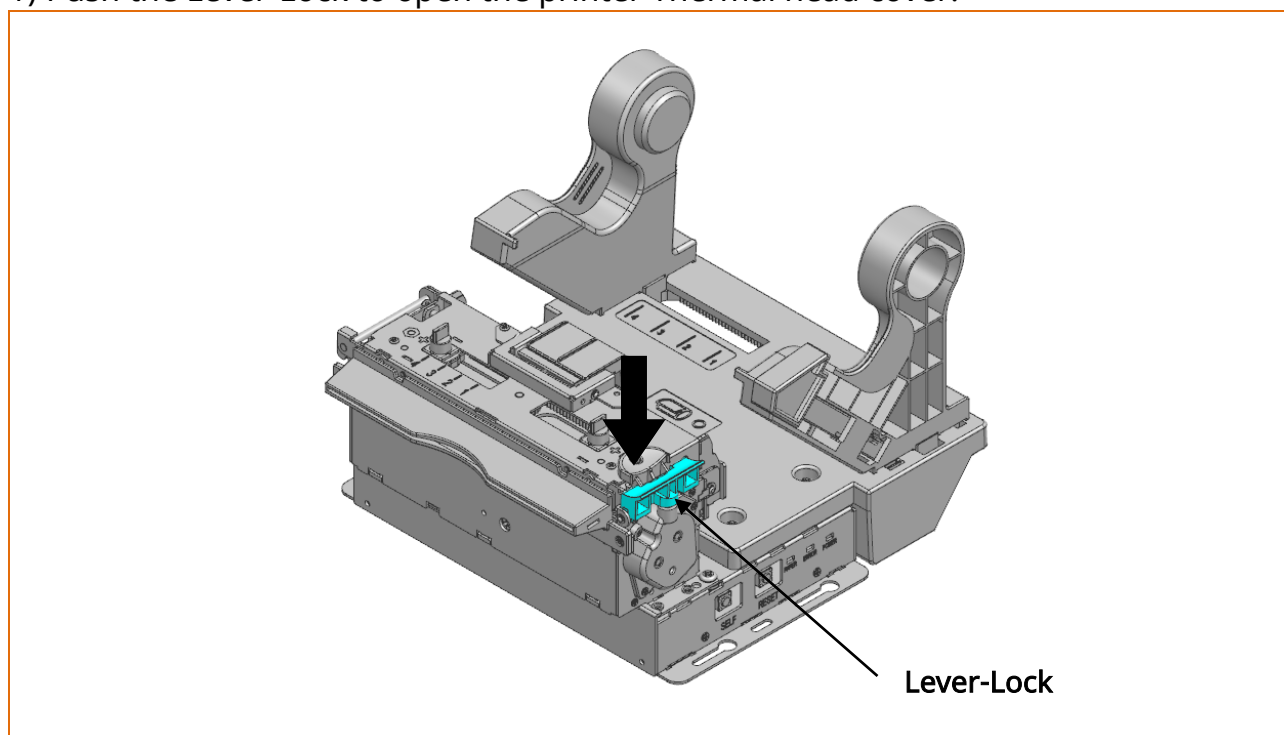

2) Install or replace the paper roll by adjusting the Holder-Paper as shown below.

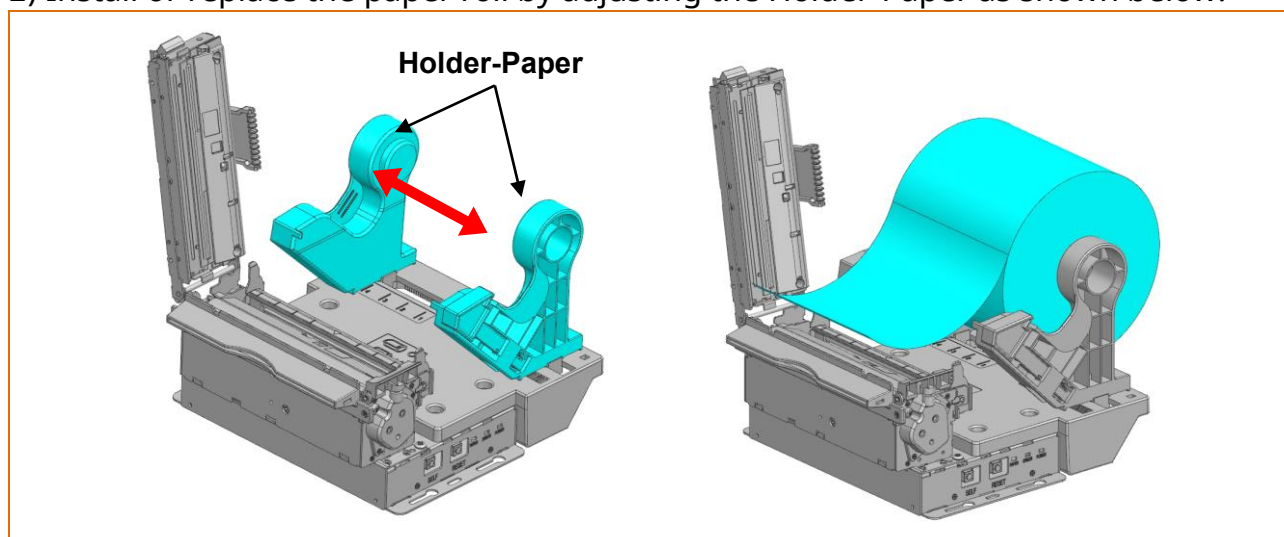

Check the orientation of the roll paper when inserting it into the printer

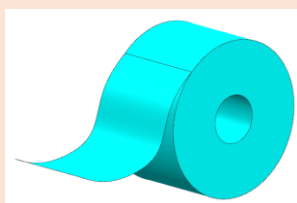

O

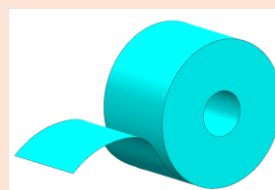

X

4) Close the Thermal head cover after pulling the paper end slightly to the front as shown below.

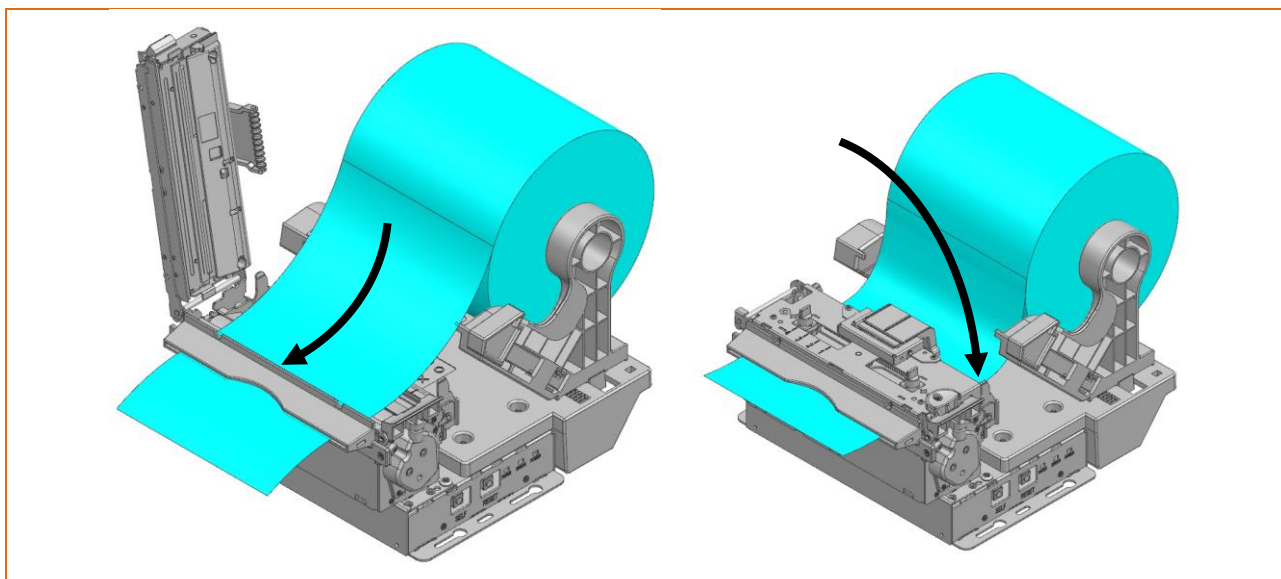

Use paper roll that complies with the specifications



- When opening or closing the Thermal head, be careful not to pinch your fingers.
- Do not open the print head levers while the printer is printing.  
Change the media when the printer is not receiving data, or data may be lost.
- While the printer is operating, the printer head gets very hot, so turn off the power and let it cool down completely.  
The hot printer head can cause serious burns.

**3-5 Adjust the Black Mark Sensor's Position**

• The BK5-41 model allows free adjustment of the Black mark sensor's position. The black mark sensor's position can be adjusted using the following steps.

- 1) Confirm the current position of the black mark sensor for the paper.
- 2) Manually adjust the black mark sensor to the desired position.

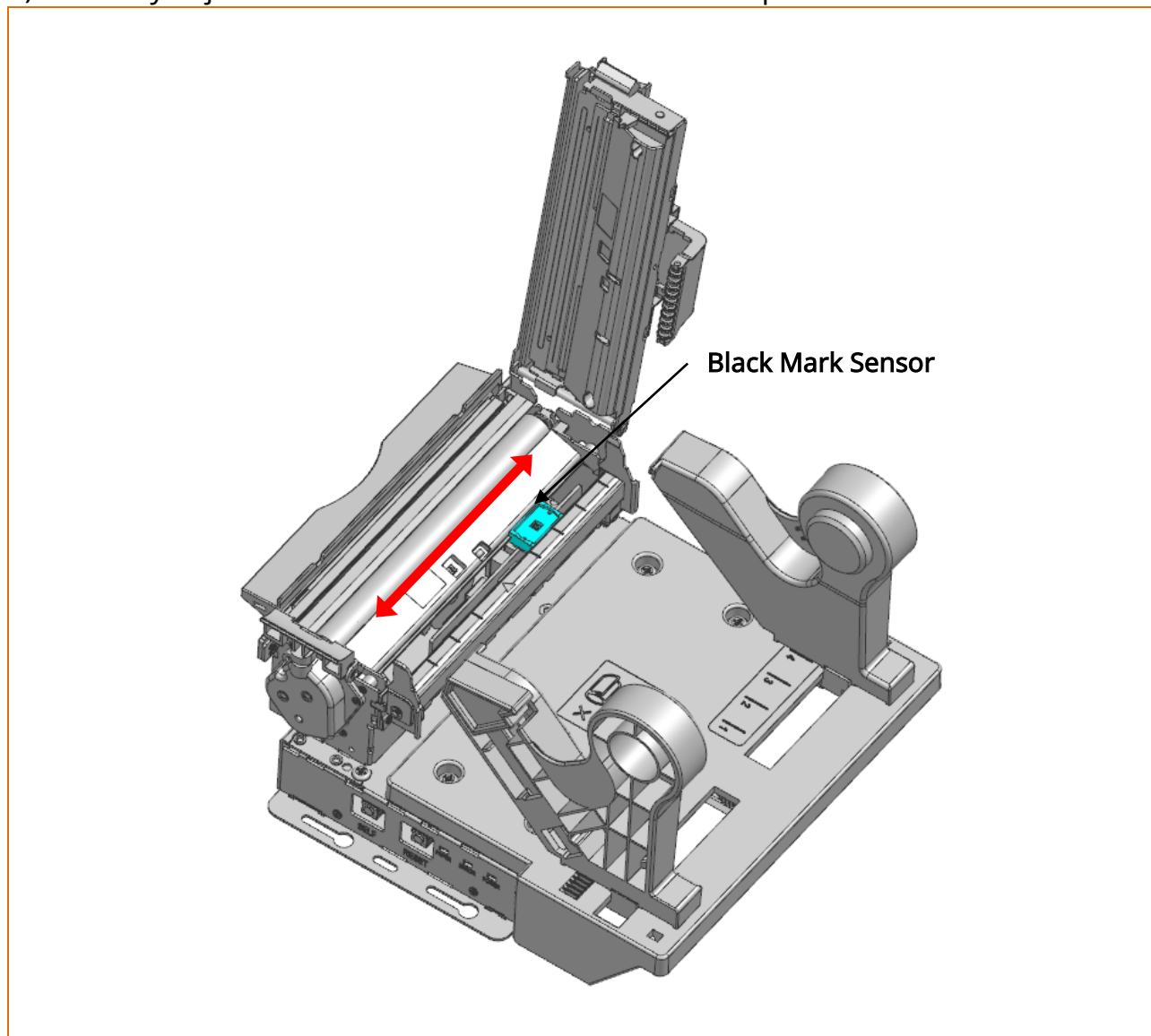

## 3-6 Using Controller



Controller	Explanation
SELF	Press the SELF button once for self-test printing. After checking the self-test printing content, press the SELF button to proceed to virtual memory setting or Hexadecimal Dump Mode if necessary.
RESET	Press the RESET button to supply power to the printer.
POWER	The Power LED light is on whenever the printer is on.
ERROR	The Error LED light turns on in case of error.
PAPER	The Paper LED light turns on when the paper roll is almost used up or there is no paper roll inside. Blinking light indicates the ready state of SELF-TEST or macro execution.

## 4. Printer Setting Change

### 4-1 Set Virtual Memory Switch

#### 1) Virtual Memory Switch 1

Switch	Function	ON	OFF	Default
1	Select print speed	*Refer to table below (Printing speed setting)		OFF
2				OFF
3				OFF
4	-	-	-	OFF
5	-	-	-	OFF
6	Select print density	*Refer to table below (Printing density setting)		OFF
7				OFF
8				OFF

Print speed	1-3	1-2	1-1	Default
150mm/s	OFF	OFF	OFF	150mm/s
130mm/s	OFF	OFF	ON	
120mm/s	OFF	ON	OFF	
100mm/s	OFF	ON	ON	

Print speed selection

Print density	1-8	1-7	1-6	1-5	Default
120%	ON	OFF	OFF	ON	100%
115%	OFF	ON	ON	ON	
110%	OFF	ON	OFF	ON	
105%	OFF	OFF	ON	ON	
100%	OFF	OFF	OFF	OFF	
95%	OFF	OFF	ON	OFF	
90%	OFF	ON	OFF	OFF	
85%	OFF	ON	ON	OFF	
80%	ON	OFF	OFF	OFF	
75%	ON	OFF	ON	OFF	
70%	ON	ON	OFF	OFF	
65%	ON	ON	ON	OFF	

Print density setting

2) Virtual Memory Switch 2

Switch	Function	ON	OFF	Default
1	Specification for destination	2byte font	1byte font	OFF
2	-	-	-	OFF
3	Code page selection	*Refer to table below		OFF
4				OFF
5				OFF
6				OFF
7				OFF
8				OFF

2-8	2-7	2-6	2-5	2-4	2-3	Code page Table	
OFF	OFF	OFF	OFF	OFF	OFF	Page 0	437 (USA, Standard Europe)
OFF	OFF	OFF	OFF	ON	OFF	Page 1	Katakana
OFF	OFF	OFF	ON	OFF	OFF	Page 2	850 (Multilingual)
OFF	OFF	OFF	ON	ON	OFF	Page 3	860 (Portuguese)
OFF	OFF	ON	OFF	OFF	OFF	Page 4	863 (Canadian-French)
OFF	OFF	ON	OFF	ON	OFF	Page 5	865 (Nordic)
OFF	OFF	ON	ON	OFF	OFF	Page 16	1252 (Latin I)
OFF	OFF	ON	ON	ON	OFF	Page 17	866 (Cyrillic #2)
OFF	ON	OFF	OFF	OFF	OFF	Page 18	852 (Latin 2)
OFF	ON	OFF	OFF	ON	OFF	Page 19	858 (Euro)
OFF	ON	OFF	ON	OFF	OFF	Page 21	862 (Hebrew DOS code)
OFF	ON	OFF	ON	ON	OFF	Page 22	864 (Arabic)
OFF	ON	ON	OFF	OFF	OFF	Page 23	Thai42
OFF	ON	ON	OFF	ON	OFF	Page 24	1253 (Greek)
OFF	ON	ON	ON	OFF	OFF	Page 25	1254 (Turkish)
OFF	ON	ON	ON	ON	OFF	Page 26	1257 (Baltic)
ON	OFF	OFF	OFF	OFF	OFF	Page 27	Farsi
ON	OFF	OFF	OFF	ON	OFF	Page 28	1251 (Cyrillic)
ON	OFF	OFF	ON	OFF	OFF	Page 29	737 (Greek)
ON	OFF	OFF	ON	ON	OFF	Page 30	775 (Baltic)
ON	OFF	ON	OFF	OFF	OFF	Page 31	Thai14
ON	OFF	ON	OFF	ON	OFF	Page 32	Hebrew Old code
ON	OFF	ON	ON	OFF	OFF	Page 33	1255 (Hebrew New code)
ON	OFF	ON	ON	ON	OFF	Page 34	Thai11
ON	ON	OFF	OFF	OFF	OFF	Page 35	Thai18
ON	ON	OFF	OFF	ON	OFF	Page 36	855 (Cyrillic)
ON	ON	OFF	ON	OFF	OFF	Page 37	857 (Turkish)
ON	ON	OFF	ON	ON	OFF	Page 38	928 (Greek)
ON	ON	ON	OFF	OFF	OFF	Page 39	Thai16
ON	ON	ON	OFF	ON	OFF	Page 40	1256 (Arabic)
ON	ON	ON	ON	OFF	OFF	Page 41	1258 (Vietnam)
ON	ON	ON	ON	ON	OFF	Page 42	Khmer (Cambodia)
OFF	OFF	ON	OFF	OFF	ON	Page 47	1250 (Czech)
OFF	OFF	ON	ON	ON	ON	Page 49	TCVN-3
OFF	ON	OFF	OFF	OFF	ON	Page 50	TCVN-3 (Capital)
OFF	ON	OFF	OFF	ON	ON	Page 51	VISCII
OFF	ON	OFF	ON	OFF	ON	Page 52	912(Albania)

3) Virtual Memory Switch 3

Switch	Function	ON	OFF	Default
1	Select emulation	*Refer to table below		OFF
2				OFF
3				OFF
4	-	-	-	OFF
5	Printing mode for Thai character	3 PASS	1 PASS	OFF
6	-	-	-	OFF
7	-	-	-	OFF
8	-	-	-	OFF

emulation	3-3	3-2	3-1	Remark
emulation 1	OFF	OFF	OFF	BXL / POS
emulation 2	OFF	OFF	ON	-
emulation 3	OFF	ON	OFF	-
emulation 4	OFF	ON	ON	-
emulation 5	ON	OFF	OFF	-



All BIXOLON software is supported only under emulation 1 (BXL/POS)

4) Virtual Memory Switch 4

Switch	Function	ON	OFF	Default
1	Swap font B and C	Enable	Disable	OFF
2	Printer buffer initialization	Enable	Disable	OFF
3	Single byte font selection (Default font)	*Refer to table below.		OFF
4				OFF
5	-	-	-	OFF
6	-	-	-	OFF
7	-	-	-	OFF
8	-	-	-	OFF

Single byte font selection	4-4	4-3	Default
font A (12 x 24)	OFF	OFF	font A
font B (9 x 17)	OFF	ON	
font C (9 x 24)	ON	OFF	
-	ON	ON	



To reset printer buffer function, open and then close the printer Thermal head cover.

5) Virtual Memory Switch 5

Switch	Function	ON	OFF	Default
1	Auto cutter selection	Disable	Enable	OFF
2	-	-	-	OFF
3	Paper save mode	*Refer to table below		OFF
4				OFF
5	Paper save mode cutting correction	Enable	Disable	OFF
6	Auto line feed (CR mode)	Processing same as LF	Ignore	OFF
7	-	-	-	OFF
8	-	-	-	OFF

Paper Save Mode	5-4	5-3	Remark
Disable	OFF	OFF	Default
Level 1	OFF	ON	-
Level 2	ON	OFF	-
Level 3	ON	ON	Only English

## 6) Virtual Memory Switch 6

Switch	Function	ON	OFF	Default
1	Internal buzzer control	Enable	Disable	OFF
2	Internal buzzer after cutting	Enable	Disable	OFF
3	Internal buzzer time	1 time	3 times	OFF
4	-	-	-	OFF
5	-	-	-	OFF
6	-	-	-	OFF
7	-	-	-	OFF
8	Select Self-Test button function	Feeding	Self-Test print	OFF

7) Virtual Memory Switch 7

Switch	Function	ON	OFF	Default
1	Print width selection	*Refer to table below		OFF
2				OFF
3				OFF
4	Black Mark Mode	Enable	Disable	OFF
5	Black mark paper near-end check	Enable	Disable	OFF
6	-	-	-	OFF
7	-	-	-	OFF
8	-	-	-	OFF

Print width	7-3	7-2	7-1	Default	Remark
108mm (864dot)	OFF	OFF	OFF	108mm	Fixed Table
104mm (832dot)	OFF	OFF	ON		
80mm (640dot)	OFF	ON	OFF		
72mm (576dot)	OFF	ON	ON		
54mm (432dot)	ON	OFF	OFF		
48mm (384dot)	ON	OFF	ON		
12mm (96dot)	ON	ON	OFF		
18mm~108mm	ON	ON	ON		Adjustable Table



- The 18mm to 108mm setting is configured using the Unified Utility (setting unit: 2mm).
- The Fixed Table and Adjustable Table cannot be configured simultaneously.
- Black mark Near-End Sensor setting (Memory Switch 7-5) can be enabled only under Black Mark Mode (Memory Switch 7-4) setting.

8) Virtual Memory Switch 8

Switch	Function	ON	OFF	Default
1	Data length	7bit	8bit	OFF
2	Parity check	YES	NO	OFF
3	Parity selection	EVEN	ODD	OFF
4	Data receive error	Ignore	Print “?”	OFF
5	Baud rate selection	*Refer to table below		OFF
6				OFF
7				OFF
8				-

Baud rate	8-7	8-6	8-5	Default
115,200bps	OFF	OFF	OFF	115,200bps
57,600bps	OFF	OFF	ON	
38,400bps	OFF	ON	OFF	
19,200bps	OFF	ON	ON	
9,600bps	ON	OFF	OFF	
4,800bps	ON	OFF	ON	
2,400bps	ON	ON	OFF	
115,200bps	ON	ON	ON	

9) Virtual Memory Switch 9

Switch	Function	ON	OFF	Default
1	Serial communication flow control	*Refer to table below		OFF
2				OFF
3	-	-	-	OFF
4	-	-	-	OFF
5	-	-	-	OFF
6	-	-	-	OFF
7	-	-	-	OFF
8	-	-	-	OFF

Serial communication flow control	9-2	9-1	Default
Hardware(DTR/DSR)	OFF	OFF	Hardware (DTR/DSR)
Software(XON/XOFF)	OFF	ON	
None	ON	OFF	
Hardware(DTR/DSR)	ON	ON	

## 10) Virtual Memory Switch 10

Switch	Function	ON	OFF	Default
1	-	-	-	OFF
2	-	-	-	OFF
3	Feed motor back-feeding	Enable	Disable	OFF
4	-	-	-	OFF
5	-	-	-	OFF
6	-	-	-	OFF
7	-	-	-	OFF
8	-	-	-	OFF

## 11) Virtual Memory Switch 11

Switch	Function	ON	OFF	Default
1~8	-	-	-	OFF

12) Virtual Memory Switch 12

Switch	Function	ON	OFF	Default
1	Select double byte country	*Refer to table below		OFF
2				OFF
3				OFF
4				OFF
5				OFF
6~8	-	-	-	OFF

Select double byte country	12-5	12-4	12-3	12-2	12-1	Remark
STD	OFF	OFF	OFF	OFF	OFF	Single byte font
KOR	OFF	OFF	OFF	OFF	ON	KS5601
JPN	OFF	OFF	OFF	ON	ON	SHIFT-JIS
CHN	OFF	ON	OFF	ON	OFF	BIG5
CHN	ON	OFF	OFF	ON	OFF	GB2312

13) Virtual Memory Switch 13

Switch	Function	ON	OFF	Default
1~8	-	-	-	OFF

14) Virtual Memory Switch 14

Switch	Function	ON	OFF	Default
1~8	-	-	-	OFF

15) Virtual Memory Switch 15

Switch	Function	ON	OFF	Default
1~8	-	-	-	OFF

16) Virtual Memory Switch 16

Switch	Function	ON	OFF	Default
1~8	-	-	-	OFF

17) Virtual Memory Switch 17

Switch	Function	ON	OFF	Default
1~8	-	-	-	OFF



- Use Unified Utility or Self-test Mode in case virtual memory switch needs to be changed.
- Refer to Unified Utility Manual for more details.



- Turn power off and on after product setting change by using virtual memory switch utility.
- All BIXOLON software is supported only under emulation 1(BXL/POS)

**4-2 PAPER/ERROR LED Response Pattern**

- The printer enters an offline state, suspending all printing work, when sensing any printing error, and the PAPER/ERROR LED light turns on.

Error	Description	LED blinking pattern	Recovery
Cover open	The cover is opened when printing.		Recovers automatically when the cover is closed.
Paper end	The paper is ended when printing.		Recovers automatically when the paper is replaced
Print head temperature	The temperature of the print head is extremely high.		Recovers automatically when the print head cools.
Auto cutter (Except for A type)	The auto cutter does not work correctly.		Recovers by Power reset.
Black mark sensor (gap) error	Black mark (gap) is not detected on paper sheets.		Automatically recovers after opening and closing cover.

## 5. Self-Test

The self-test checks whether the printer has any problems.

If the self-diagnostics reveal no error in the printer, please see other device or software. If the printer does not run normally, please contact the place of purchase.

- 1) Check whether paper is inserted correctly.
- 2) Self-test starts when SELF button is pressed when the power is on.
- 3) The printer will print out details of its current status including which version of ROM.
- 4) After printing the current status, the printer stops with the printed message below.  
(The paper LED will continue to be on.)

**Press the button continuously with below number,  
You can enter the mode what you want.  
(Procedure off if no touching over 2 sec)**

**1 : VMSM selection mode  
2 : Hexadecimal dump mode  
3 or more : Exit**

- 5) Press the SELF button once for Memory Switch Setting Mode, twice for Hexadecimal Dump Mode.
  - Press the button 3 times or more to finish the self-test.
  - After printing, if button is not pressed for 2 seconds, the self-test will auto-finish.

(1) When Memory Switch Setting Mode is selected:

- ① Messages below are printed after entering Memory Switch Setting Mode.

**\*\* Memory Switch Setting Mode \*\***

**0 : Exit and reboot printer**

**1 : Print current settings**

**2 : Set Serial Interface**

**3 : Set Print Density**

**4 : Set Print Speed**

**5 : Set Auto Cutter**

**6 : Set Print width**

**7 : Set Code Page**

**8 : Factory Reset**

**9 or more : None**

- ② Press SELF button as below to enable above functions.

- Step 1 (Select the setting item): Press the button in short intervals as noted times to select the setting item.

- Step 2 (Enter the setting item): Long press the button for 1 second to enter the selected setting item.

- ② Execute "0: Exit and reboot printer" to reflect the changed setting.  
Printer will print message below and reboot.

**\*\*\* Complete \*\*\***

(2) When Hexadecimal Dump Mode is selected:

- ① Messages below are printed after entering Hexadecimal Dump Mode.

**Hexadecimal dumping**  
**To terminate hexadecimal dump**  
**press SELF button three times**

- ② Execute the program to transfer data to the printer.  
 The printer prints out all data in 2 columns.  
 The first column indicates the hexadecimal code  
 and the second column shows corresponding ASCII characters to the code.

1B 21 00 1B 26 02 40 40 40 40	. ! . . & . @ @ @ @
02 0D 1B 44 0A 14 1E 28 28 28	... D . . . . ( ( (
00 01 0A 41 0D 42 0A 43 43 43	... A . B . C C C

- Period(.) will show when no corresponding ASCII code exists.
- Under hexadecimal code print mode, all commands are disabled.

- ③ Press the SELF button 3 times to finish hexadecimal dump.
- ④ Message below is printed after finishing Hexadecimal Dump Mode

**Hexadecimal Dump Completed.**



- Normal operation of the printer can be confirmed by performing the self-test.
- Self-test provides print quality check, ROM version info., and memory switch setting.



- If SELF button is not pressed for 2 seconds after self-test printing, self-test will auto-finish.
- If "0: Save settings and exit" is not executed, the setting information is not stored in the printer.
- Contact the store if Hexadecimal Dump Mode cannot be entered.



## 6. Black Mark (Gap) Sensor Auto-Calibration

The printer is developed to recognize the black mark (gap) paper. However, for some special papers, the printer may not detect the black mark (gap). In this case, black mark (gap) sensor auto-calibration should be performed using the following steps.

- 1) Close the Thermal head cover after removing the paper with the printer powered off.
- 2) Turn on the power with SELF button pressed.
  - Keep pressing the button until PAPER LED and ERROR LED lights are both blinking.
  - Once the PAPER LED and ERROR LED are blinking, the mode has changed.
- 3) Open the Thermal head cover to place the paper inside and close the Thermal head cover.
- 4) Black mark (gap) sensor calibration starts.

While printing, the sensor calibration is performed and black mark (gap) distance is measured.
- 5) The printer will auto-reboot after complete calibration.



Black mark (gap) sensor auto-calibration is necessary in the cases below.

- If the printer is operated for the first time
- If the paper type is changed
- If the printing output is not accurate or does not stop at normal position

## 7. Product Specifications

### 7-1 Set Serial number Classification

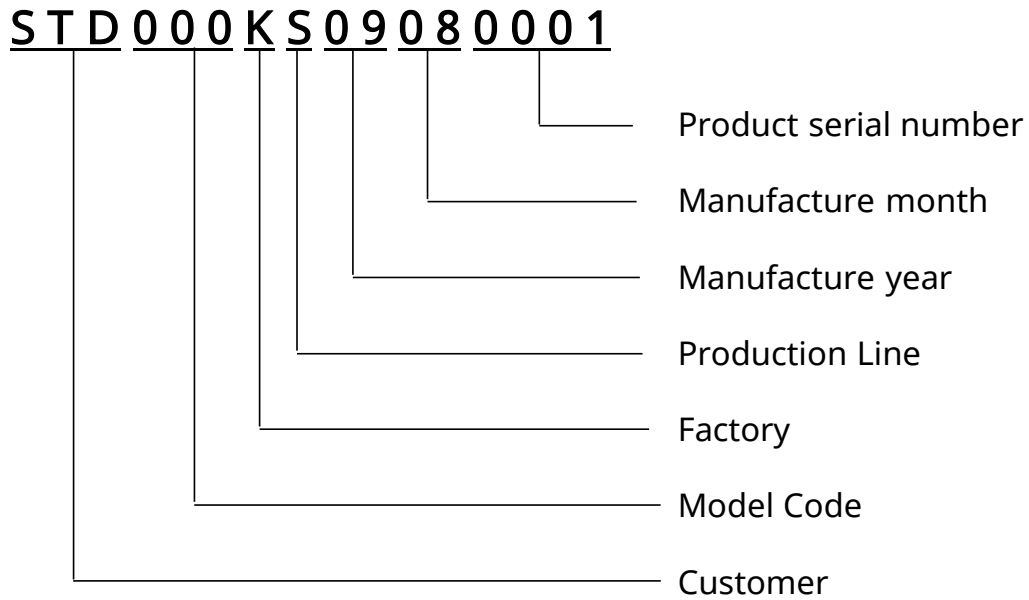

### 7-2 Printer Classification

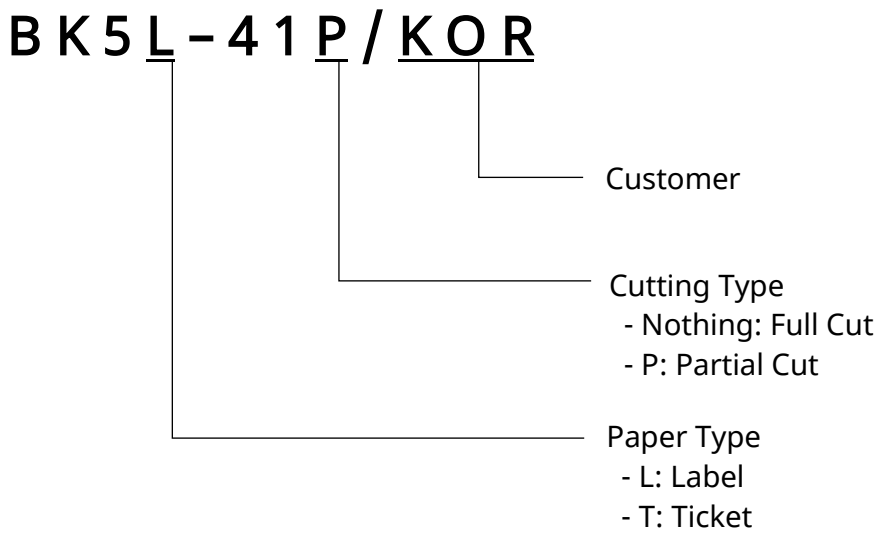

## 7-3 Printer Specification

Printing Method		Thermal printing						
Dot Density		203 dpi (8dots/mm)						
Paper Width (mm)		112	108	83	80	60	58	20
Printing Width (mm)		108	104	80	72	54	48	12
No. of Characters per Line (Default)	font A (12x24)	72	69	53	48	36	32	8
	font B (9x17)	96	92	71	64	48	42	10
	font C (9x24)	96	92	71	64	48	42	10
	Korean (24x24)	36	34	26	24	18	16	4
Printing Speed		150mm/s						
Font size	font A (12x24)	1.50 x 3.00mm						
	font B (9x17)	1.13 x 2.13mm						
	font C (9x24)	1.13 x 3.00mm						
	Korean (24x24)	3.00 x 3.00mm						
Number of Characters		English: 95 characters						
		Extension character (code page): 128 x 37 page (including blank space code page)						
		Other countries: 32 characters						
Barcode	1D	UPC-A, UPC-E, JAN13(EAN), JAN8(EAN), CODE39, ITF, CODABAR, CODE93, CODE128, GS1-128, GS1 DataBar Omni-direction, Truncated, Limited						
	2D	PDF417, QR code(model 1/2), Data Matrix , GS1 Databar Stacked, Stacked Omni-directional						
Auto Cutter		Full cut / Partial Cut						
Interface	Serial	RS232C compliance						
	USB	V2.0 Full speed compliance						
Receiving Buffer Size		30K bite						
AC/DC Adapter	Input Voltage	100~240 VAC						
	Frequency	50/60 Hz						
	Output Voltage	24 VDC						
	Output Current	Constant current: 2.5A, Peak current: 11A (Holding time: over 0.1ms)						
Environment Condition	Temperature	Operating: -20 ~ 60 °C (*1) Storage: -20 ~ 60 °C						
	Humidity	Operating: 10 ~80% RH Storage: 10 ~ 95 % RH Under non-condensed state, excluding papers						
Life Span	Mechanism Head (*2)	50 Km (Label)						
	Auto Cutter	300,000 Cut (Ticket) 1,500,000 Cut (Label: Liner basis)						

\*1) Print quality and product lifecycle is warranted only under 0–40°C condition. Long-term operation out of guided condition may cause shorter product lifecycle.

\*2) The guided condition is based on the standard temperature, designated space, and factory initial state, and subject to change per temperature and printing level.

Especially when using label paper other than the recommended one (Hansol, unprinted white paper),

since the printed color on the paper may transfer to the TPH and shorten its lifespan,

the warranty will not be applied, so please make sure to check and do not use it. • Printing speed may vary in accordance with the combination of data

transmission speed and different commands.

- Label paper whose gap length is 2mm or less is unusable.

- Label paper whose length is 30mm or less is unusable.

- Label paper must not exceed 0.15 mm in thickness.



The company is not liable for any product quality issues arising from using AC/DC adaptor non-complying with standard specification.

## 7-4 Paper Specification

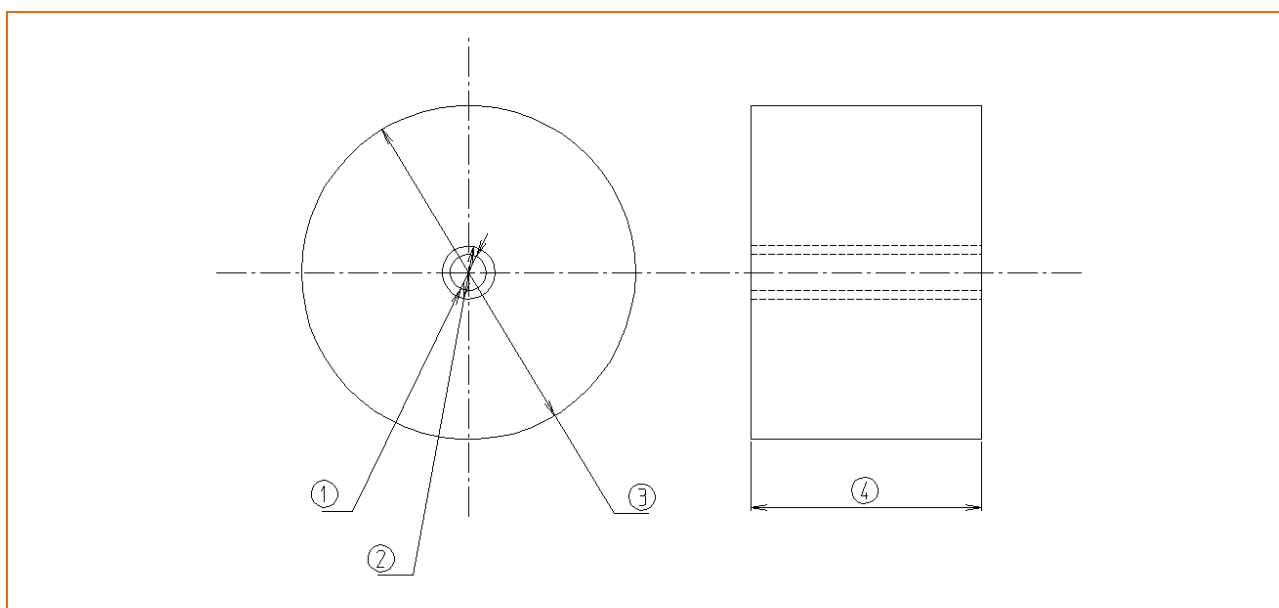

1. Holder inner diameter (mm)	$\Phi 25 +3,0$
2. Holder outer diameter (mm)	$\Phi 31$ (Minimum)
3. Paper roll outer diameter (mm)	$\Phi 130$ (Maximum)
4. Paper width (mm)	20 ~ 118
5. Paper thickness (mm)	0.05 ~ 0.15



If sticking issue (feeding failure due to TPH and paper being stuck) occurs, adjust the printing density and speed.

## 7-5 Kiosk system specifications

When designing your kiosk system, keep in mind the following points.

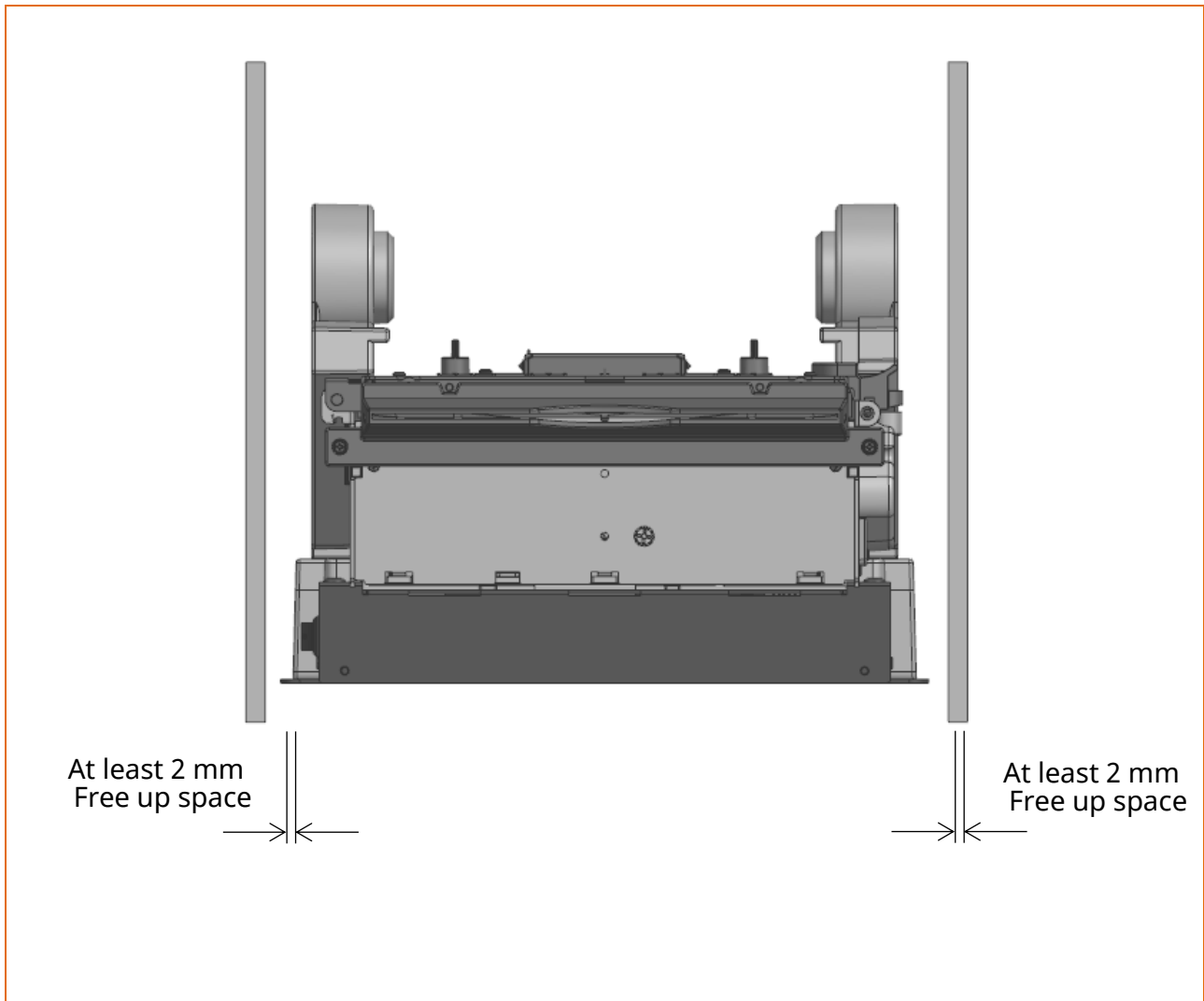

- Allow at least 2 mm of printer and assembly tolerance.
- We are not liable for any issues related to product performance or quality.

7-6 Outer dimensions

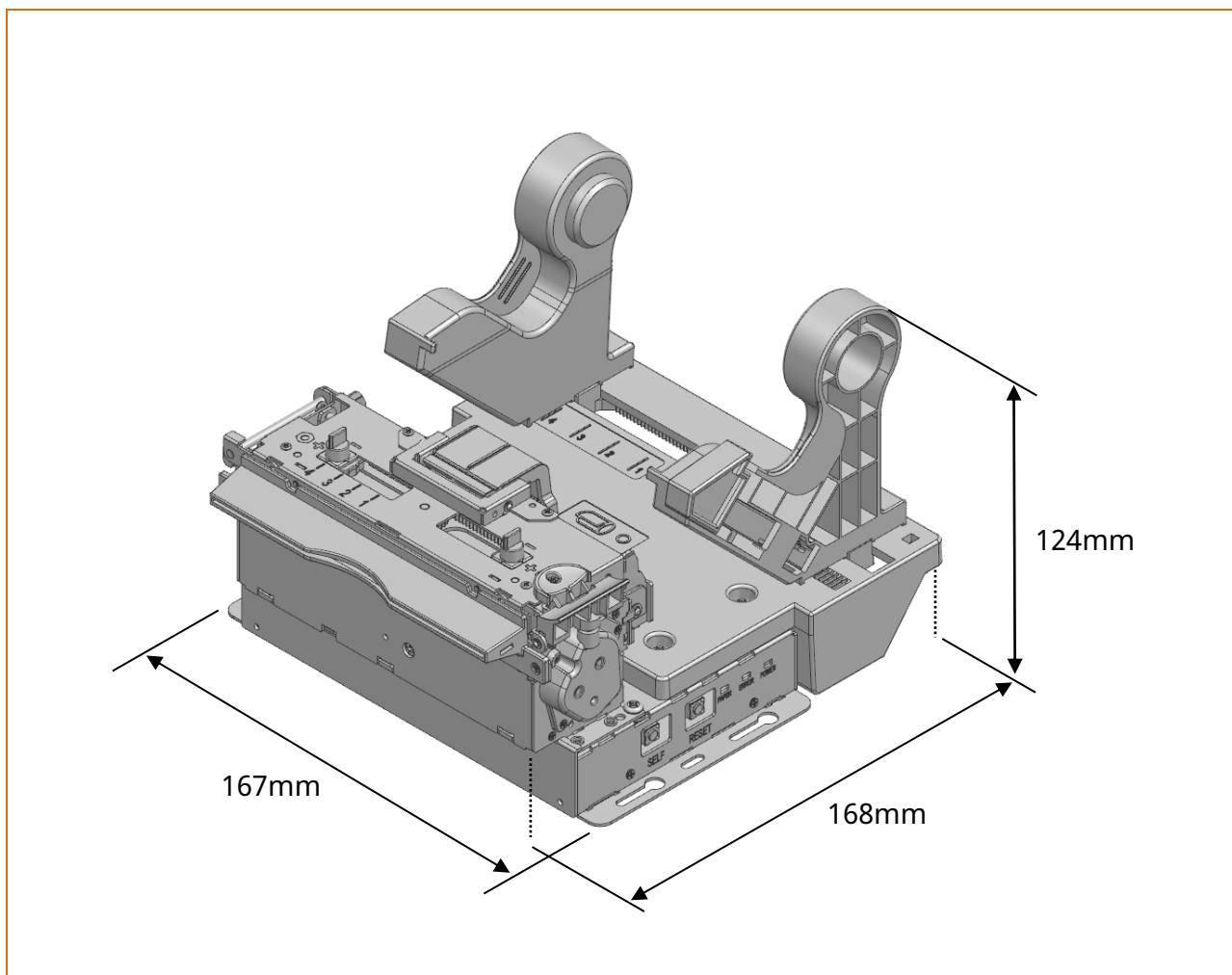

# BK5-41

Unit: mm

Typical tolerance:  $\pm 0.3$

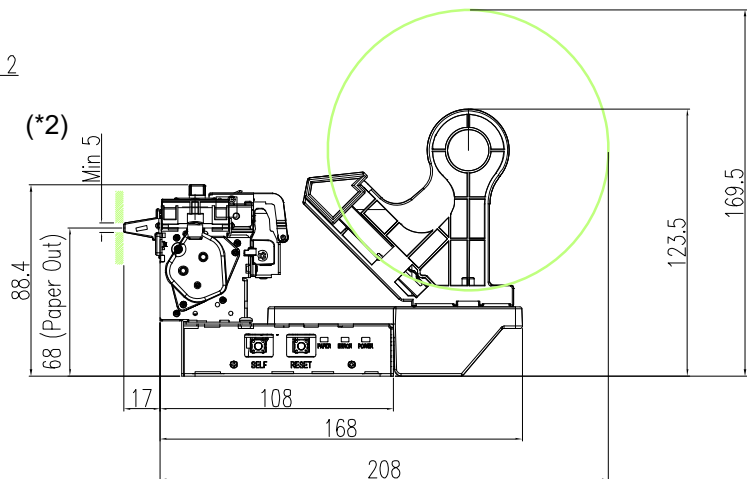
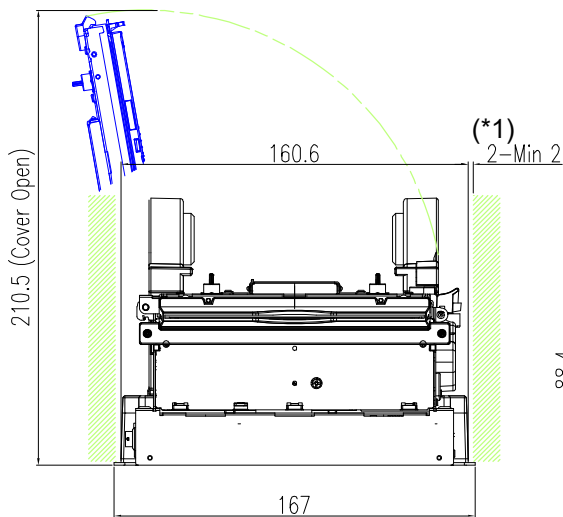
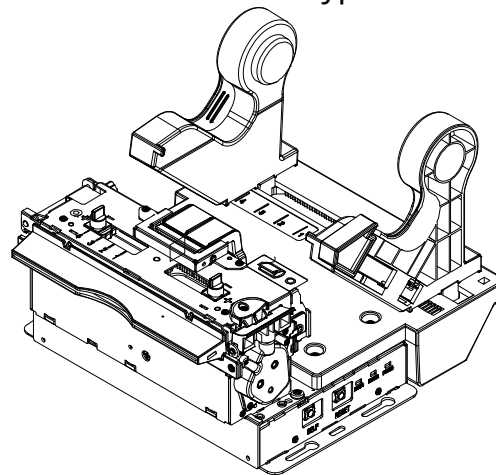
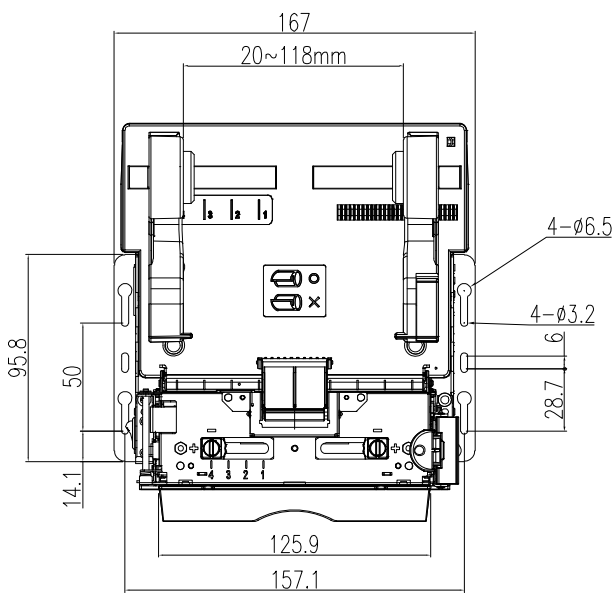

- Ensure that the printer has a ceiling height of at least 130 mm.
- The Paper outline space must be at least 5mm.

## 7-7 Communication and Port Specification

### 7-7-1 Interface Specifications

#### 1) Serial

Item	Description	Remark
Data Transmission	Serial	-
Synchronization	Asynchronous	-
HandShaking (Flow Control)	H/W : DTR/DSR S/W : XON/XOFF	XON : ASC Code 11h XOFF:ASC Code 13h
Signal Level	Logic1 (MARK): -3V ~ -15V Logic0 (SPACE): +3V ~ +15V	-
Baud Rate	2400/4800/9600/19200/38400/57600/115200 Bps	-
Data Word Length	8 bit	-
Parity	None, Even, Odd	-
Connector	DSub 9P Male (Model: BK5L-41a/b)) 20017WR-05A00(Model: BK5L-41c/d)	-



The Handshaking (Flow Control) / Data Word Length / Baud Rate / Parity functions depend on the Memory Switch settings..

#### 2) USB

Item	Description	Remark
Transfer Type	BULK	-
Data Signal	Bi-direction, Half-Duplex Differential Signal Pair (D+ / D-)	-
Data Format	NRZI Format Zero Bit Stuffing after 6 ones	-
Speed	12 Mbps	-
Power	Self-Powered	-
Cable & Connector	Cable : 1.8m Connector : B Type(Device) / A Type(Host)	-
Other	Supports the Full-speed mode (FS) for USB 2.0, as well as the low-speed (LS modes) for USB 1.1	-

7-7-2 Port Specification -1

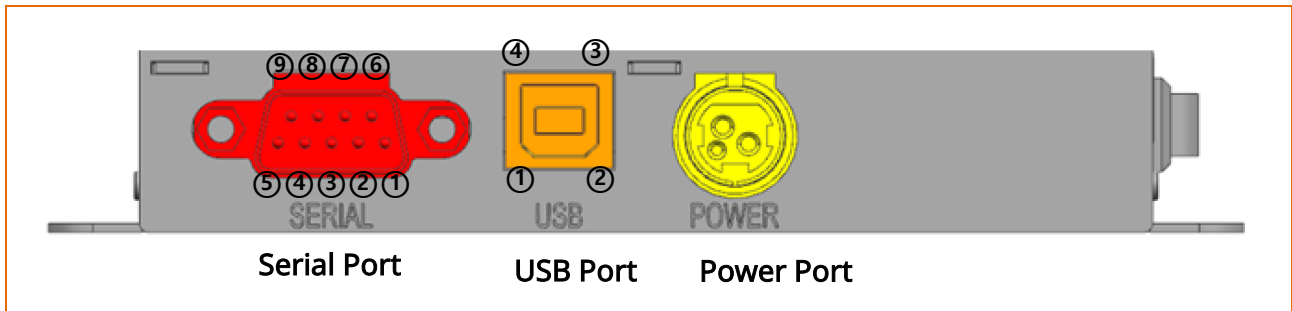

1) Serial Port(Dsub 9P Type)

DSUB 9 Pin No.	Signal name	Signal Direction	Function
1	NC	-	-
2	RxD	Input	Receive Data
3	TxD	Output	Transmit Data
4	DTR	Output	Data Terminal Ready
5	GND	-	Signal Ground
6	DSR	Input	Data Set Ready
7	RTS	Output	Ready To Send
8	CTS	Input	Clear To Send
9	NC	-	-

2) USB Port(USB B Type)

Pin No.	Signal name	Assignment (Color)	Function
Shell	Shield	Drain Cable	Frame Ground
1	VBUS	Red	Host Power: DC5[V] / 500[mA]
2	D-	White	Differential Data Line
3	D+	Green	Differential Data Line
4	GND	Black	Signal Ground

3) Power Port(DC-Jack type)

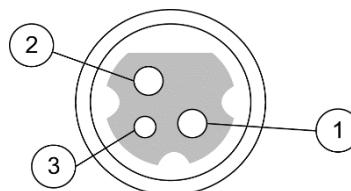

Pin No.	Signal name
Shield	Frame Ground
1	+24VDC
2	GND
3	N.C

## 8. Hardware(Wiring Diagram)

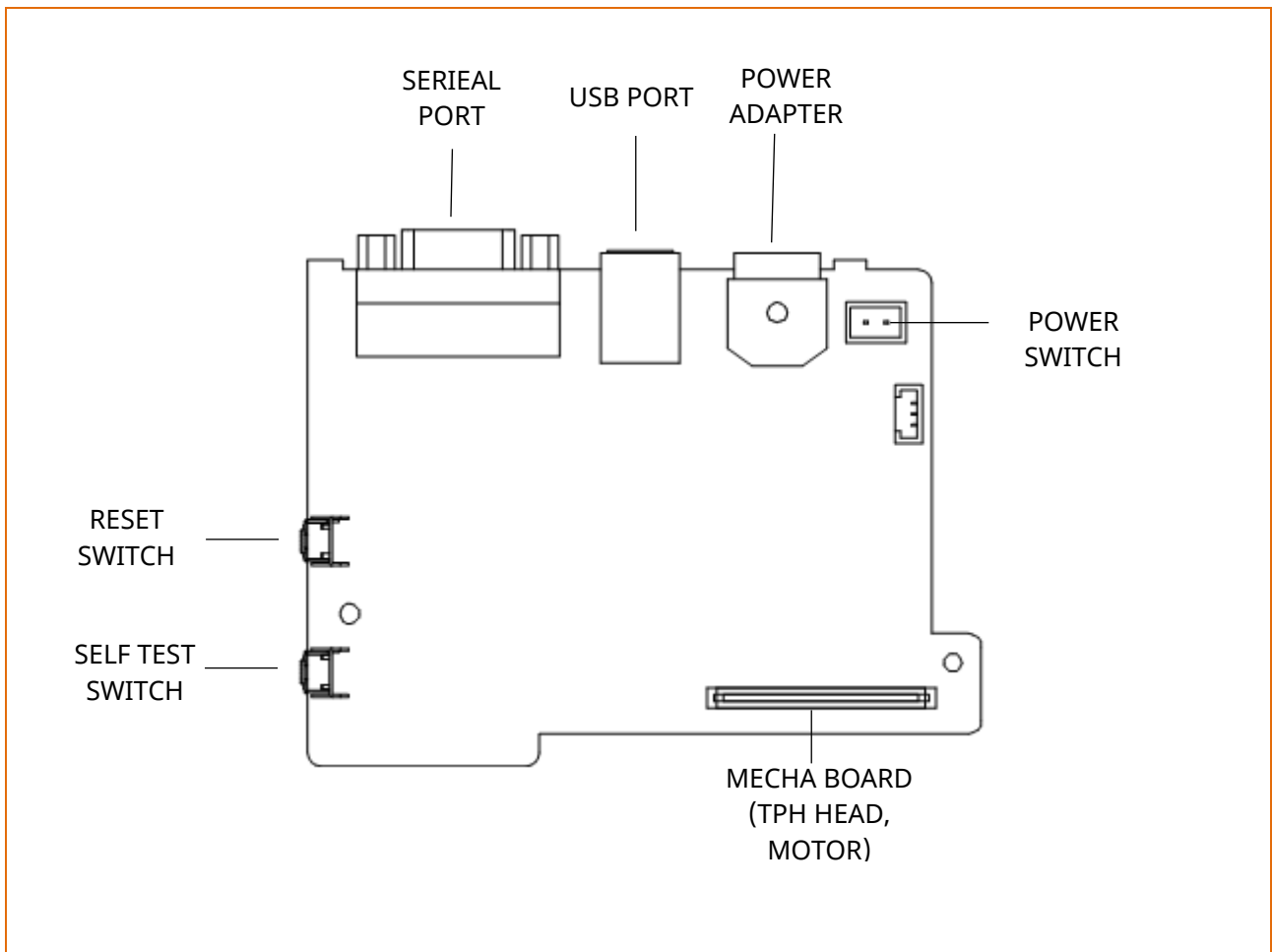

## 9. Maintenance

### 9-1 Paper Jam

- If paper is stuck, turn the printer ON/OFF and open the Printer Thermal head Cover to remove the crumpled paper inside the printer. If the Thermal head cover will not open, please follow the following instructions.

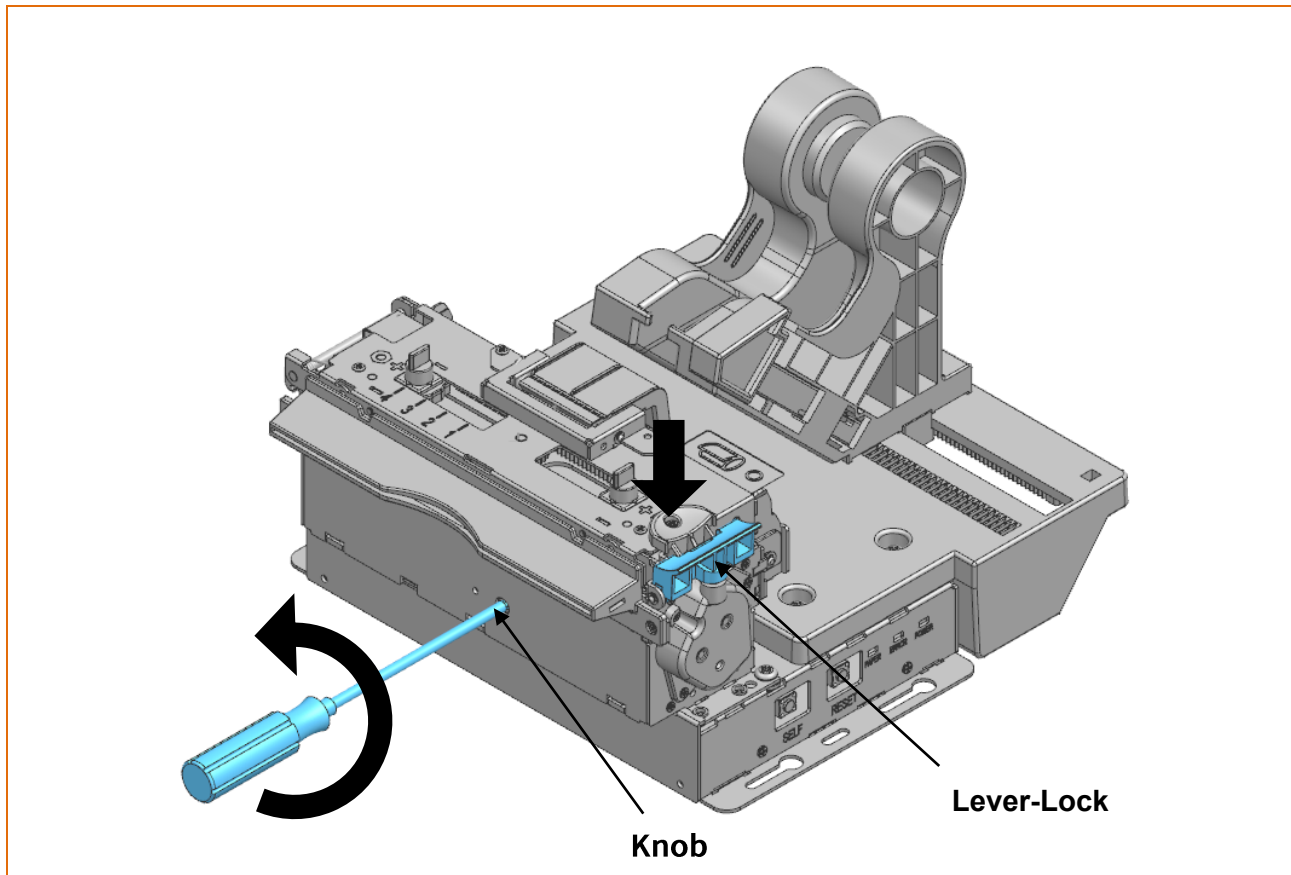

- 1) Turn the printer OFF.
- 2) Using a crosshead (+) screwdriver, turn the gear parts to insert extruded blade.
- 3) Turn the Printer Thermal head cover ON and use it.



**If the Thermal head cover does not open, do not forcibly open it. It may result in poor paper cutting or printer damage.**



- Placing your hand above the printer outlet may cause a paper jam.
- In case of a minor jam, it may be possible that the operating blade returns to the original position by turning the printer OFF and then back ON.
- Secure a minimum of 5mm allowance for paper outlet space to prevent paper jamming when designing a kiosk (Check note on outer dimension in 7-3-3)

## 9-2 Cleaning Printer

- The presence of dust, foreign matter, adhesive matter, or other pollutants inside the printer's head and internal capacity may undermine printing quality. It is recommended to clean printer at every paper roll change.

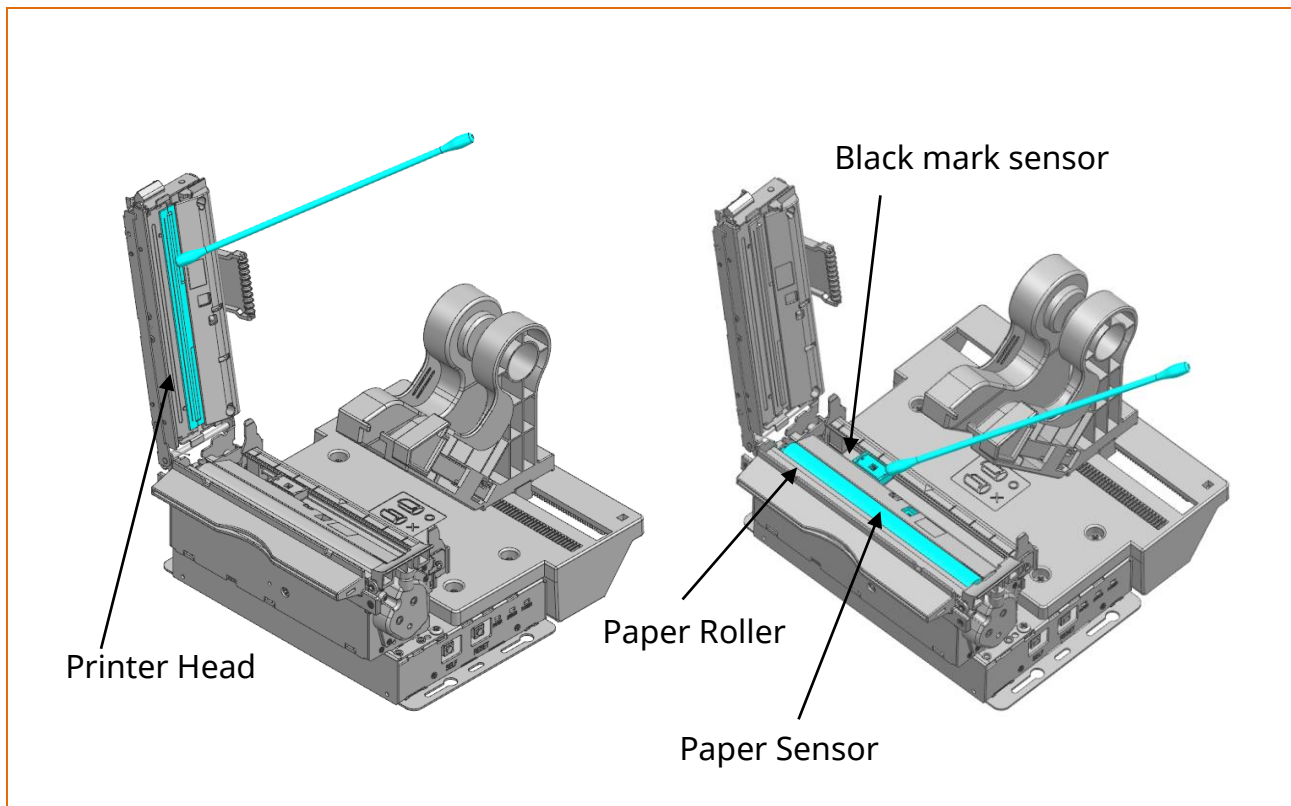

- 1) Open the printer Thermal head cover and remove the paper currently in use.
- 2) Residue or contamination of printer head should be wiped out by alcohol for medical.
- 3) Clean the paper sensor and paper roller with a cotton swab or a dry cloth.
- 4) Clean the cutter blade with a cloth wet with medical alcohol.
- 5) Insert a paper roll and close the printer Thermal head cover.



- Be sure to clean after turning the printer off.
- Be careful not to leave scratches in the print head  
The printer may be damaged.
- Print head is very hot while the printer is printing, so clean the printer after cooling it sufficiently with power off.
- Do not touch heated area of print-head when cleaning.  
Personal injury may result from static electricity, etc.

# 10. Troubleshooting

## 10-1 Troubleshooting flow chart

• If the source of a problem is not clear, use the flowchart below to find and replace a defective component. Normally, servicing should be performed by component replacement. Repairs of the PCBs and other components should be performed only by technicians.

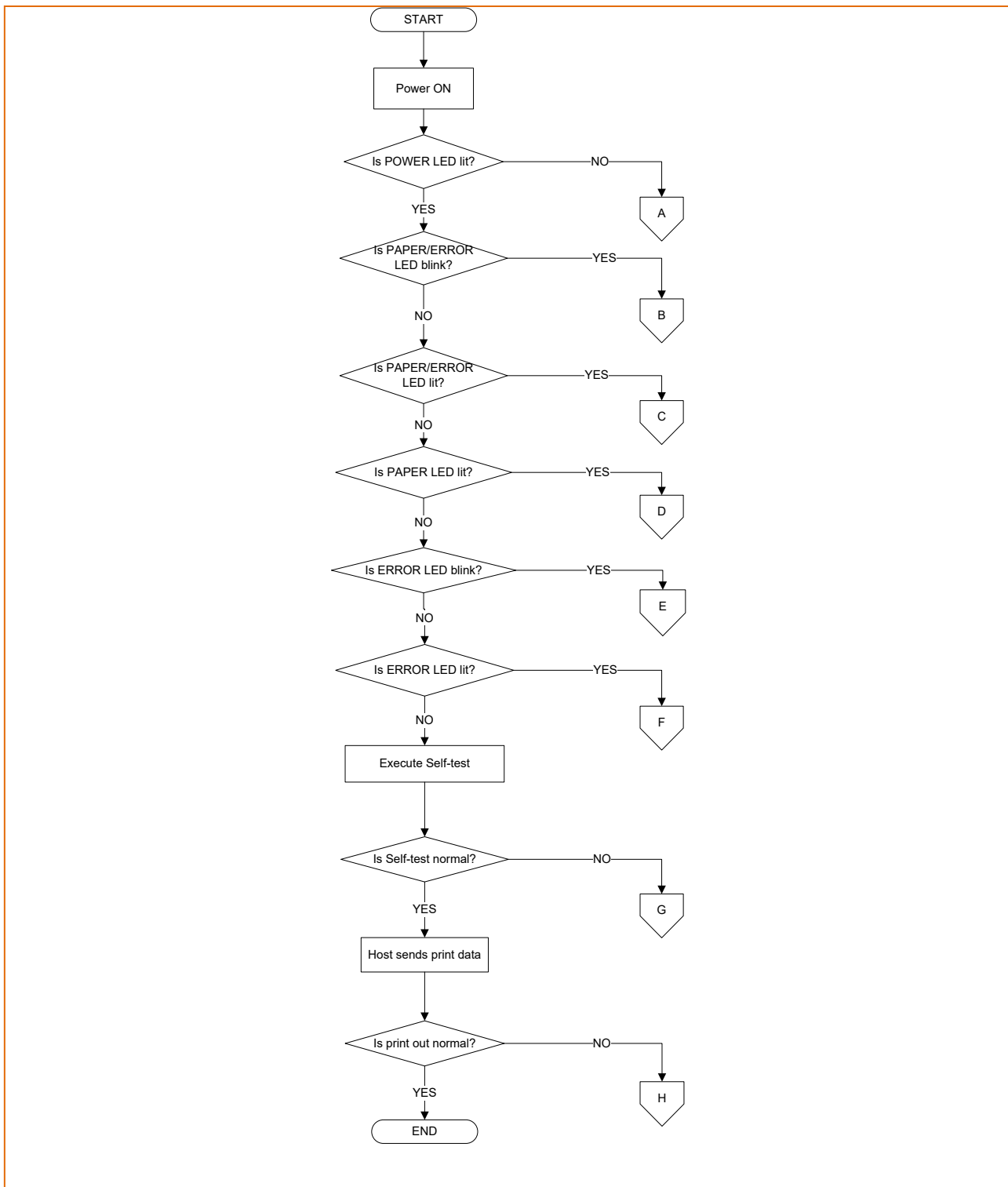

10-2 (A) POWER LED does not light

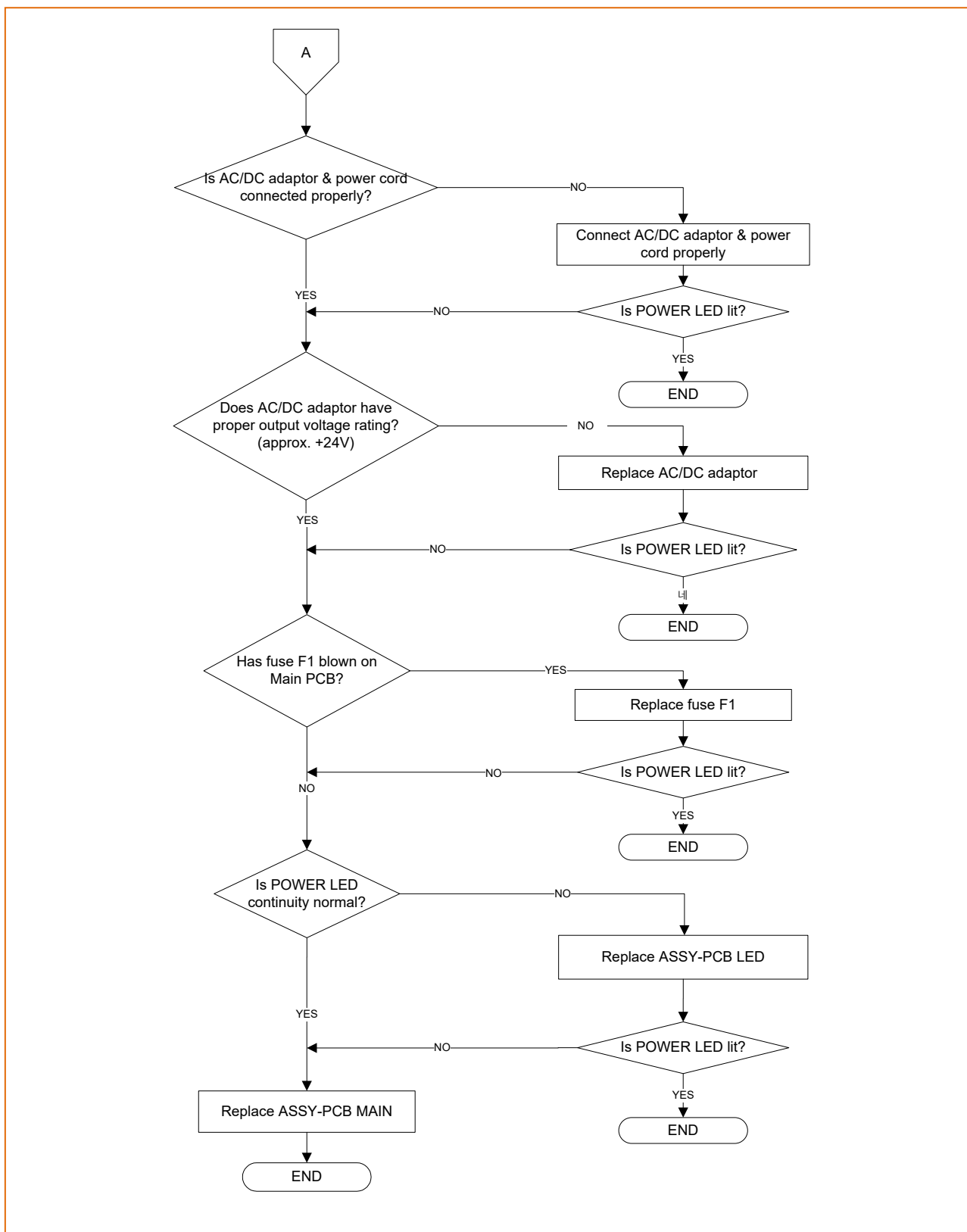

10-3 (B) PAPER and ERROR LEDs blink

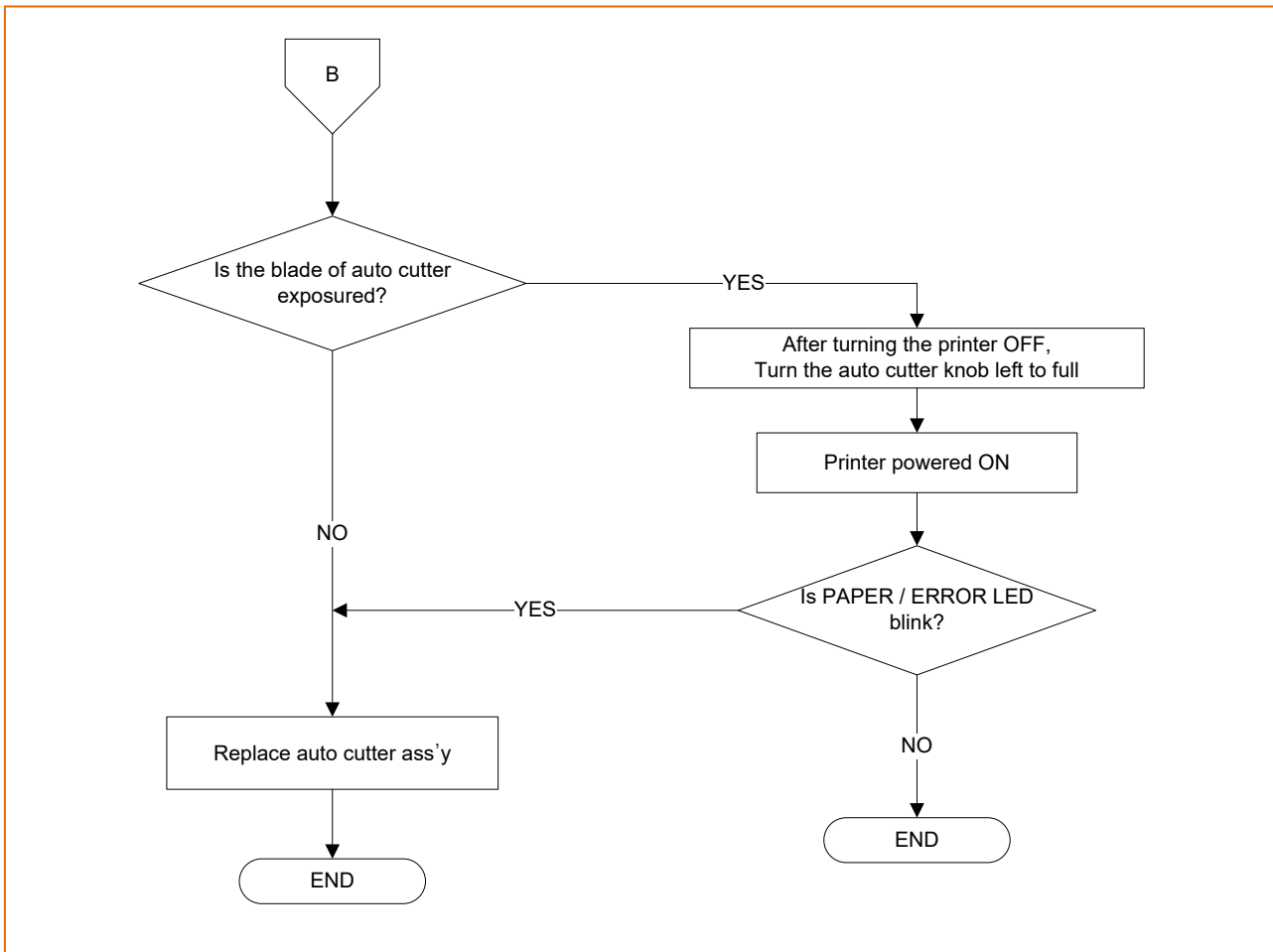

10-4 (C) PAPER and ERROR LEDs lit

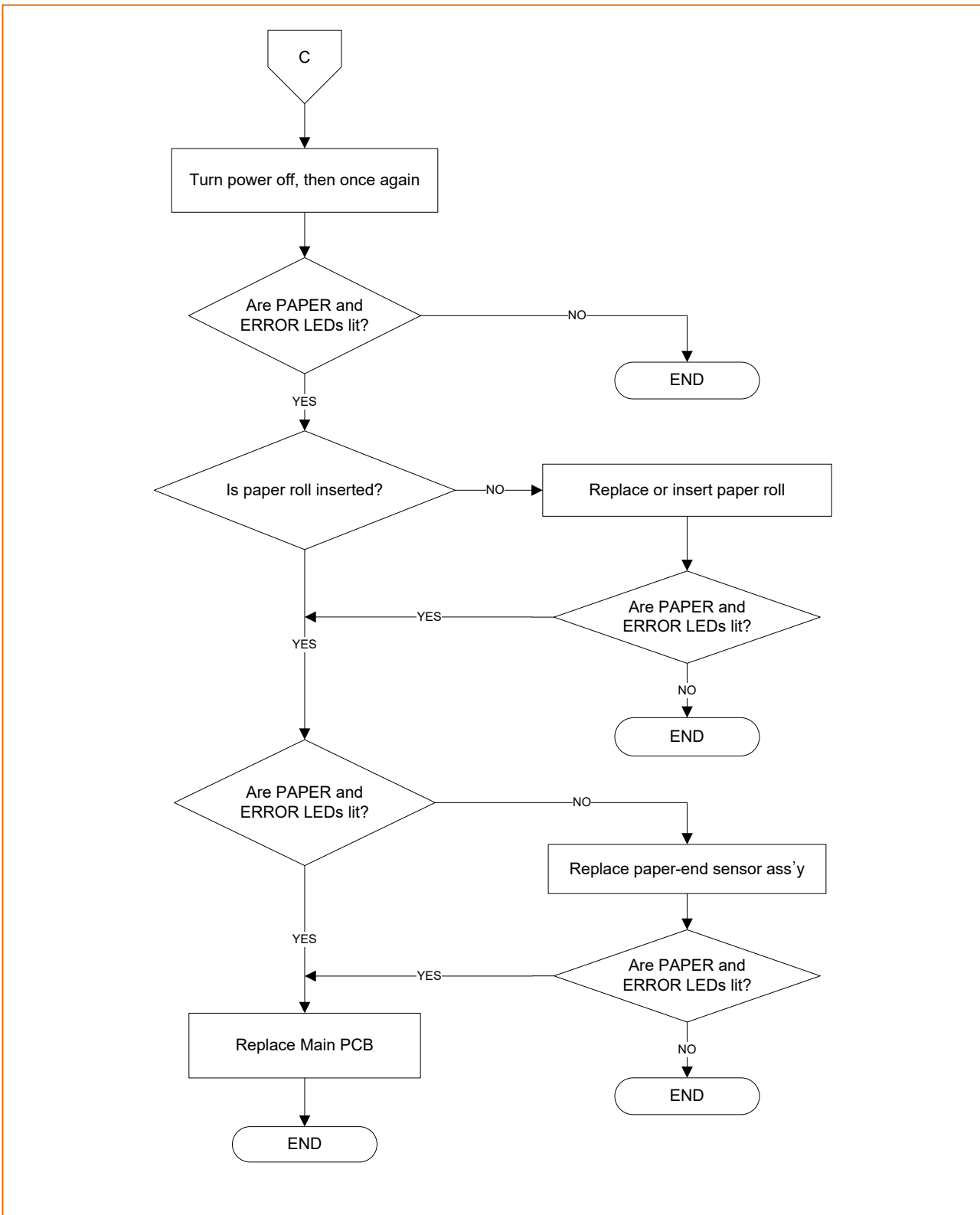

10-5 (D)PAPER LED lit

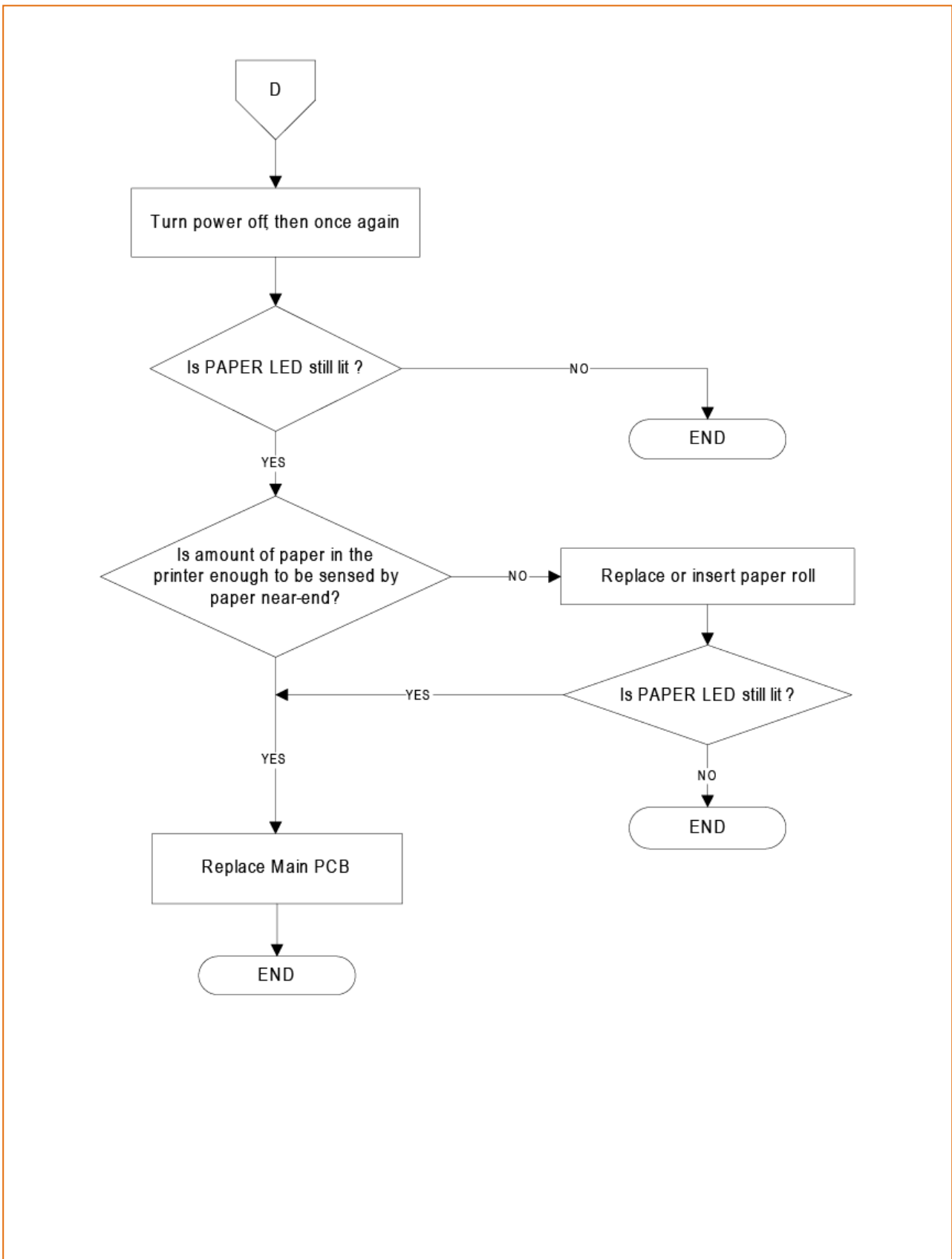

10-6 (F)ERROR LED lit

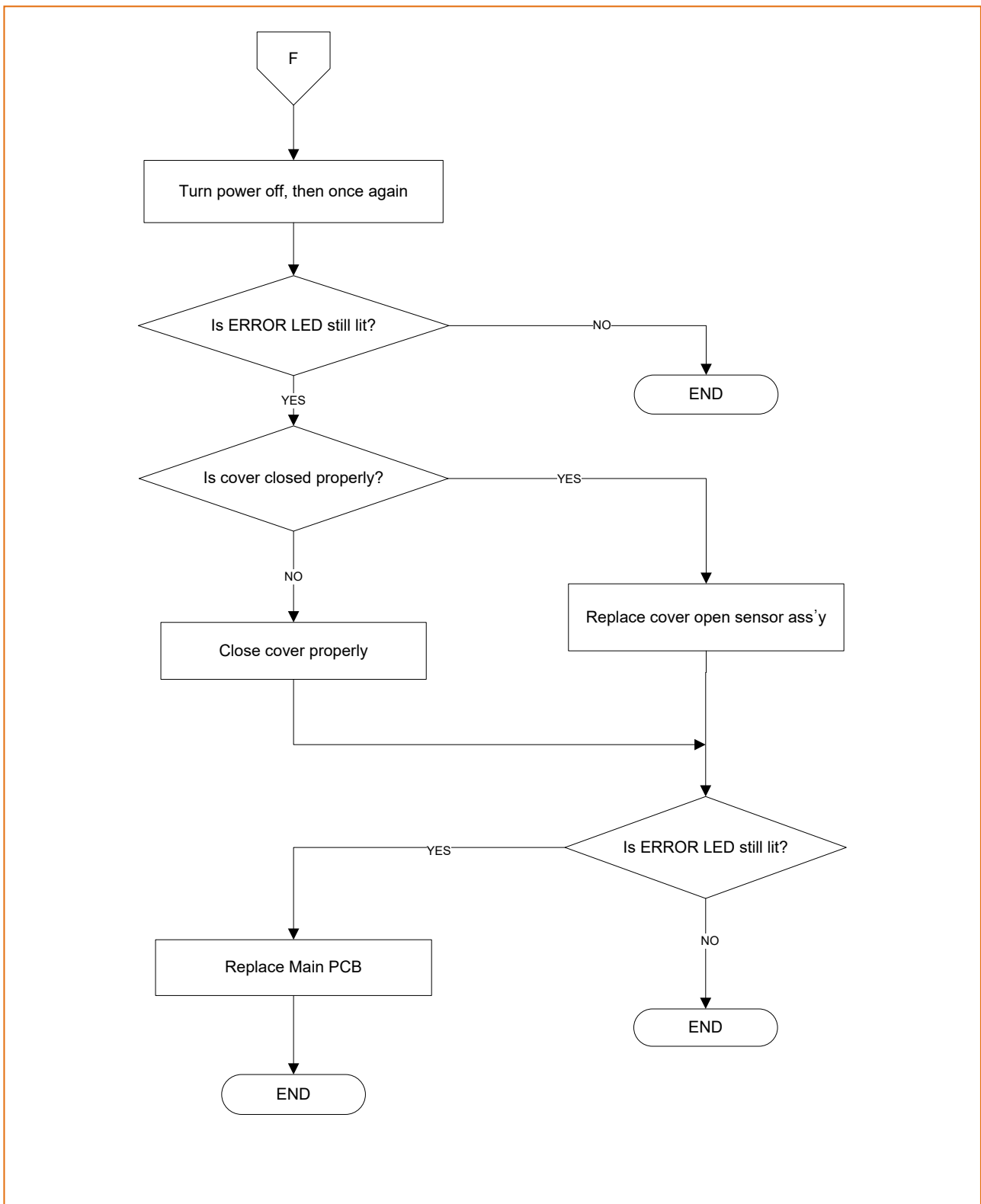

10-7 (G) Self test is not printed

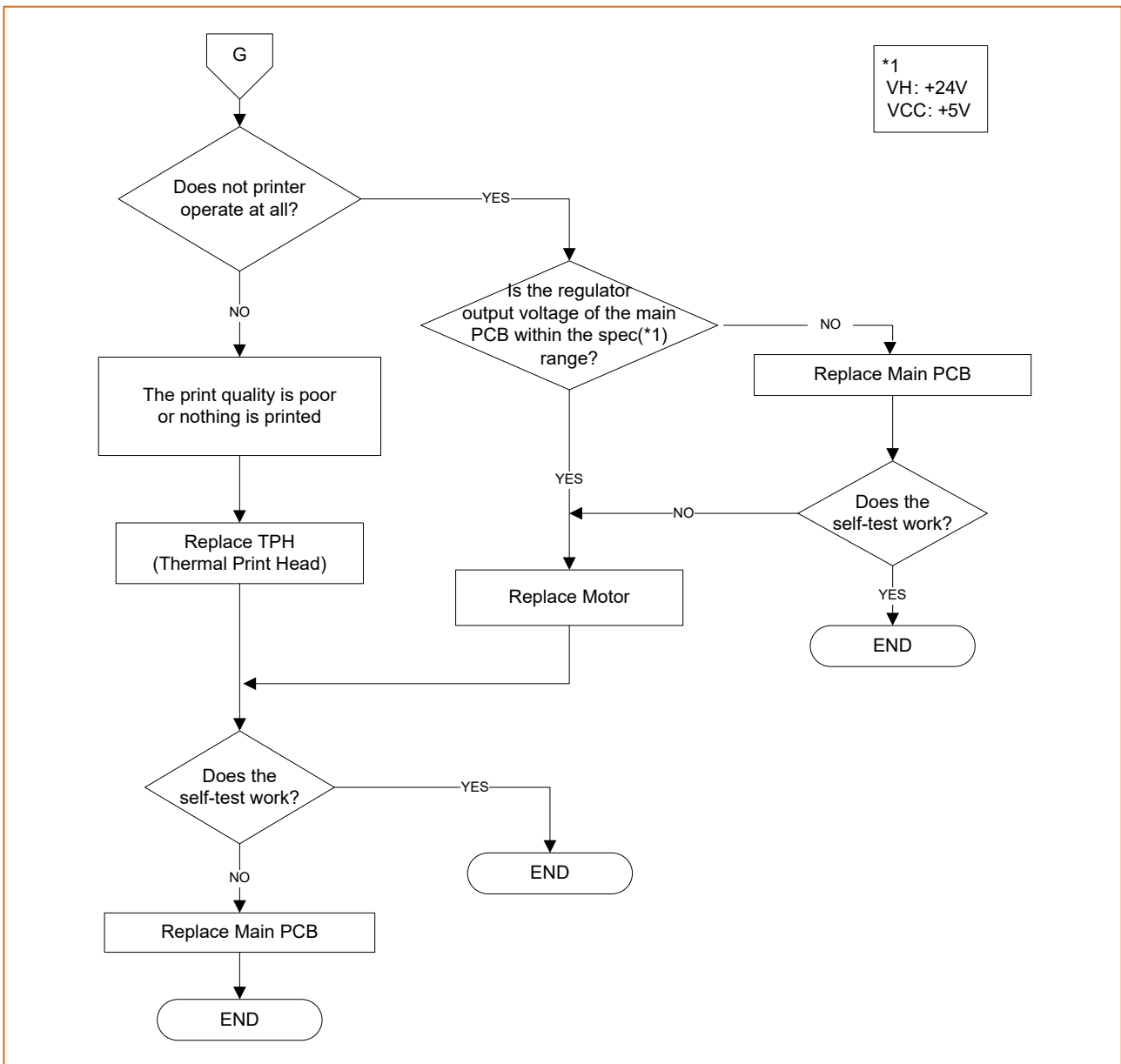

10-8 (H)Data from host is not printed normally

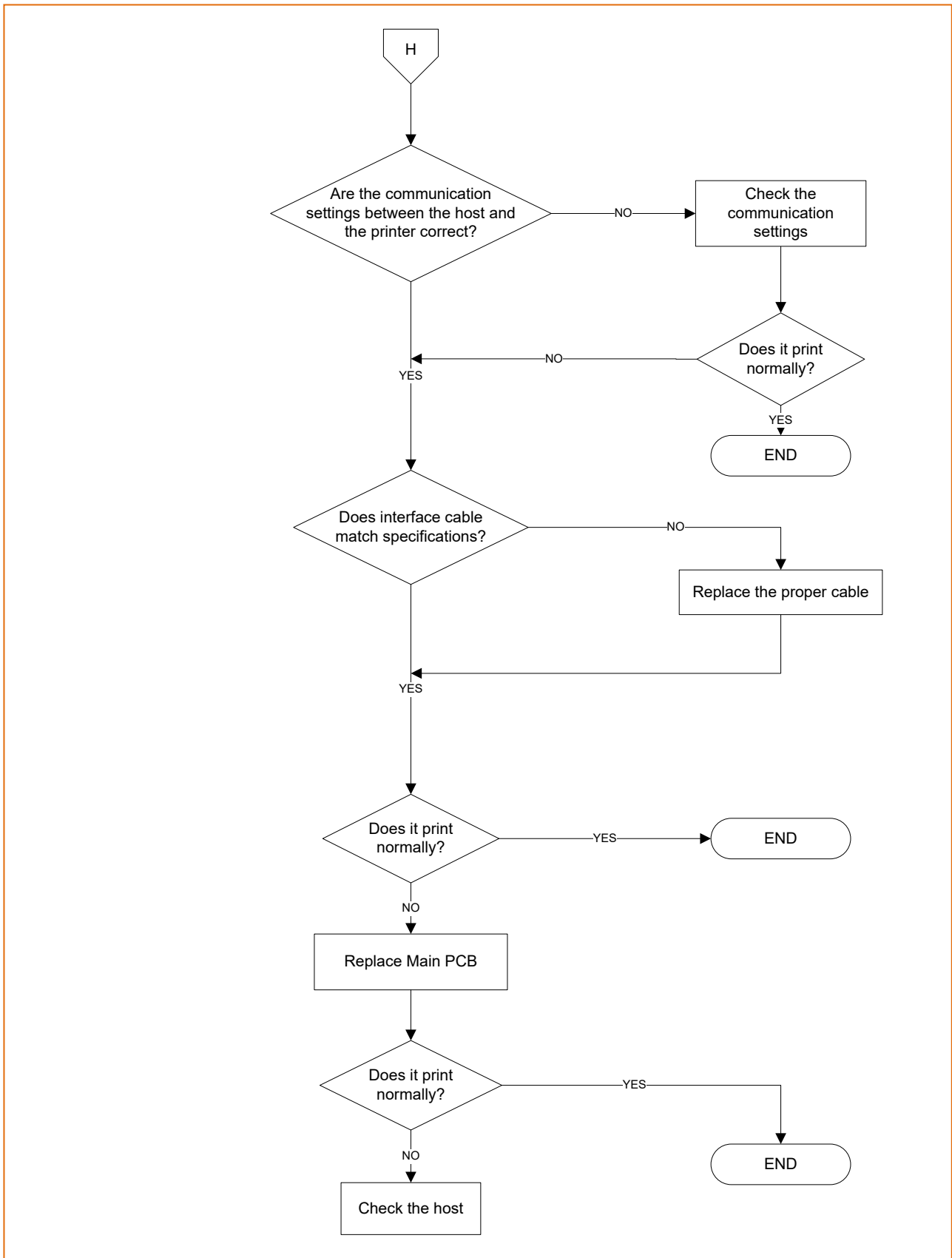

**10-9 Power Problem**

- If a problem that can be verified by visual examination has occurred, use the tables below to determine the cause and perform repairs.

There are four tables, divided by symptom category:

- Printing Quality Problems
- Printer Mechanism Problems
- Auto cutter Mechanism Problems

The tables contains the following columns:

- Problem  
This is the symptom that can be verified
- Problem Causes  
This is a listing of one or several possible causes that should be examined.
- Level
  - Level A  
The problem can be corrected by persons who are familiar with the printer and have general knowledge, but special technical skills are not required.
  - Level B  
The problem requires thorough knowledge and familiarity with the printer as well as technical skills and experience.
- Checkpoint  
These are one or more areas in the printer that should be checked.
- Action  
These are the steps to correct the problem. If the problem persists after taking these steps, check the other possible causes listed.

## 10-9-1 Printing Quality Problems

Problem	Probable Cause	Level	Checkpoint	Action
Certain parts are printed with vertical white lines	Foreign substance on the head surface	A	Check the foreign substance on the head surface	Remove the foreign substance with a cleaning pen
	Head surface is damaged	B	Check the damage of the head surface such as dents	Replace the head
	Internal IC of the head is damaged	B	Damage of the internal IC of the head	Replace the head
	Vertical scratched trace on the paper	A	Check whether there are obstructions such as bumps	Remove the obstructions
Certain parts are printed with vertical black lines	Damage to the internal IC of the head	B	Damage of the internal IC of the head	Replace the head
Horizontal black lines are generated or the vertical width of the characters is reduced	Irregular feeding	B	Check for damage to the gears and for foreign substances in the gear profile	Replace the gears or remove the foreign substance
	Feeding motor failure	B	Check whether the motor runs smoothly without load	Replace the motor
	Roller rotation is not smooth	A	Check whether oil remains in the bearings holding the roller	Add oil for the bearings
Overall printing density is low	Roller and the head are not attached properly	A	Cover is not completely closed	Open the cover, then and completely close it
	The spring pushing the head is not strong enough	B	Check whether the screws mounting the spring are loose	Fasten the screws
	Head surface is damaged	B	Check for abrasions on the head surface	Replace the head

## 10-9-2 Mechanism Problems

Problem	Probable Cause	Level	Checkpoint	Action
Paper feeding failure	Feeding motor failure	B	Check for short failure inside the motor	Replace the motor
	Gear is dislocated from the rotating axis	B	Check the assembly status of the washers holding the gears	Reassemble the gears and washers
	Paper jam	B	Check for paper jam	Open the cover, and then remove the jammed paper
	Auto cutter jam	B	Check for auto cutter jam	Open the cover cutter, and then restart the printer
Cover cannot be opened when pressing the button	Auto cutter jam	B	Check for auto cutter jam	Open the cover cutter, and then restart the printer
Cover cannot be closed	Deformation of Hook	B	Check for deformation of Hook	Straighten the Hook with =pliers
Error LED is on and there is a long and continuous beep sound while the printer is in the ready state.	Cover Open sensor failure	B	Check for sensor failure	Replace the sensor Ass'y
Error LED is on and there is a short and continuous beep sound while the printer is in the ready state.	Paper End sensor failure	B	Check the sensor failure	Replace the sensor Ass'y
Error LED is on and there is no beep sound while the printer is in the ready state.	Near-End Sensor failure	B	Check for sensor failure	Replace the sensor Ass'y
Joint or bouncing sound during feeding operation	Gears are damaged or are impeded by foreign substances	B	Check for damage or foreign substances on the gears	Replace the gears or remove the foreign substance
Entered characters and printed characters are different	Check the communication speed	A	Communication speed is set by Memory switches for Serial Mode	Check the Memory switch setting
	Communication cable failure	A	Check RS-232C null modem Cable	Replace the cable

10-9-3 Auto Cut Mechanism Problems

Problem	Probable Cause	Level	Checkpoint	Action
Auto cutter does not work at all	Memory switch setting failure	A	Check whether Memory switch 5-1, 5-2 is ON	Change ON to OFF
	Contaminants in the auto-cutter sensor	A	Check for contaminants in the cutter sensor	Remove contaminants from cutter sensor

